

Service manual

Gear pumps - series X

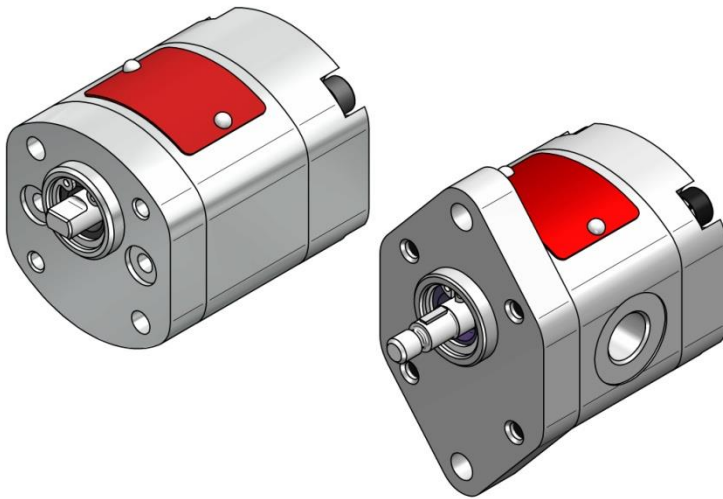

1. Basic description

The gear pumps serve for changing the mechanical energy into pressure head of the liquid. Pumps of X series are designed for use in hydraulic systems with very low performance (up to 2.3 kW). They are produced in unidirectional and bi-directional design. The X series have a wide spectrum of usable rotational speed from 800 to 8000 min⁻¹, enabling connection to high-speed motors.

2. Table of parameters

Nominal Size Parameters		Symb.	Unit	X-0,18	X-0,25	X-0,32	X-0,36	X-0,40	X-0,50	X-0,63	X-0,70
Nominal displacement		V_g	[cm ³]	0,18	0,25	0,32	0,36	0,40	0,50	0,63	0,70
Rotation speed	nominal	n_n	[min ⁻¹]	1500							
	minimum	n_{min}	[min ⁻¹]	1000							
	maximum	n_{max}	[min ⁻¹]	8000	7000			6000			
Pressure at the inlet port	minimum	p_{1min}	[bar]	-0,3							
	maximum	p_{1max}	[bar]	0,5							
Pressure at the outlet port	maximum continuous	p_{2n}	[bar]	200	230				220		
	maximum	p_{2max}	[bar]	250						240	
	peak	p_3	[bar]	260						250	
Nominal flow rate (min.) at n_n and p_{2n}		Q_n	[dm ³ .min ⁻¹]	0,19	0,30	0,40	0,44	0,50	0,65	0,85	0,95
Maximum flow rate at n_{max} and p_{2max}		Q_{max}	[dm ³ .min ⁻¹]	1,39	1,77	2,27	2,50	2,83	2,98	3,74	4,22
Nominal input power (max.) at n_n and p_{2n}		P_n	[kW]	0,10	0,17	0,22	0,24	0,28	0,34	0,41	0,46
Max. input power at n_{max} and p_{2max}		P_{max}	[kW]	0,69	0,88	1,12	1,24	1,40	1,47	1,78	2,01
Weight		m	[kg]	0,37	0,38	0,38	0,38	0,39	0,39	0,40	0,40

Nominal Size Parameters		Symb.	Unit	X-0,80	X-1,00	X-1,25	X-1,50	X-2,00	X-2,50	X-3,20	
Nominal displacement		V_g	[cm ³]	0,80	1,00	1,25	1,50	2,00	2,50	3,20	
Rotation speed	nominal	n_n	[min ⁻¹]	1500							
	minimum	n_{min}	[min ⁻¹]	1000	800			600	500		
	maximum	n_{max}	[min ⁻¹]	6000	5000	4000	3000	2800	2500	1800	
Pressure at the inlet port	minimum	p_{1min}	[bar]	-0,3							
	maximum	p_{1max}	[bar]	0,5							
Pressure at the outlet port	maximum continuous	p_{2n}	[bar]	220	200		160	120	90	60	
	maximum	p_{2max}	[bar]	240	220		180	150	100	70	
	peak	p_3	[bar]	250	230		190	160	110	80	
Nominal flow rate (min.) at n_n and p_{2n}		Q_n	[dm ³ .min ⁻¹]	1,05	1,35	1,70	2,00	2,70	3,40	4,45	
Maximum flow rate at n_{max} and p_{2max}		Q_{max}	[dm ³ .min ⁻¹]	4,78	4,95	4,98	4,50	5,56	6,20	5,69	
Nominal input power (max.) at n_n and p_{2n}		P_n	[kW]	0,52	0,59	0,74	0,71	0,71	0,66	0,56	
Max. input power at n_{max} and p_{2max}		P_{max}	[kW]	2,27	2,16	2,17	1,60	1,65	1,23	0,79	
Weight		m	[kg]	0,40	0,41	0,41	0,43	0,45	0,48	0,53	

3. Working liquid

- Mineral oils for hydraulic drives (NBR seal)
- Hydraulic liquids based on vegetable oils, suitable for hydrostatic drives (NBR seal)
- Cooling liquid and ozone (CR seal)

3.1. Liquid temperature

- $t = -20 \div +80$ [°C] (NBR seal)
- $-20 \div +120$ [°C] (FKM seal)
- $-30 \div +120$ [°C] (CR seal)

3.2. Kinematic viscosity of liquid [$m^2 \cdot s^{-1}$]

- recommended (for continuous operation) 20.10⁻⁶ to 100.10⁻⁶
- maximum when put in operation (at kinematic viscosity 1200.10⁻⁶
>1000 allowed service pressure is <10 bar
speed < 1500 RPM)
- minimum (operating mode at 10.10⁻⁶ to 20.10⁻⁶ has to be 10.10⁻⁶
consulted with the producer)

10.10⁻⁶

3.3. Filtration coefficient $\beta\alpha$

- $\beta_{25} 75 \geq$ (for pressure $p_2 < 200$ bar)
- $\beta_{10} 75 \geq$ (for pressure $p_2 > 200$ bar)

3.4. Contamination level – class of liquid ISO 4406

- 19/16 (for pressure $p_2 < 200$ bar)
- 17/14 (for pressure $p_2 > 200$ bar)

3.5. Contamination level – class of liquid NAS 1638

- 10 (for pressure $p_2 < 200$ bar)
- 8 (for pressure $p_2 > 200$ bar)

4. Pump drive

Driving mechanism must cause neither the axial nor radial load of the pump shaft. In case of the operation with the load of the driving shaft, the pump must be equipped with the front-end bearing. The driving mechanism must meet the specified tolerances of the position, see the Figure No. 1. The usage of flexible coupling is recommended.

The tolerance of the driving mechanism position:

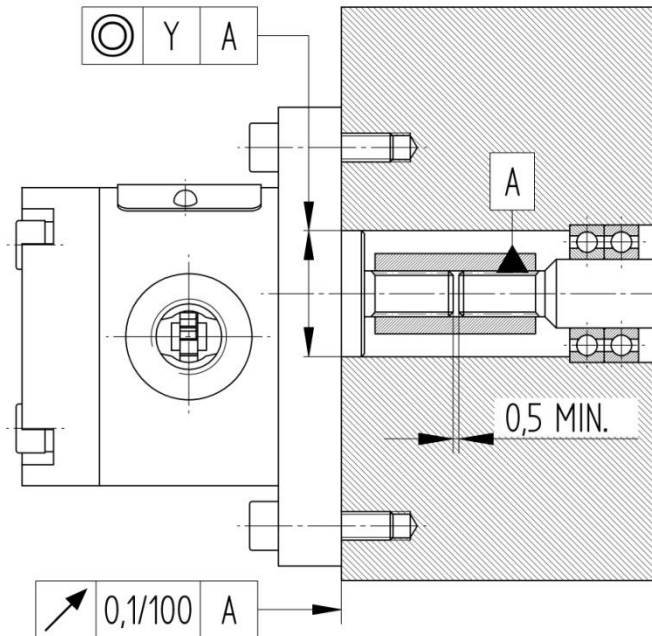

Figure No. 1

Coupling used for the of the torque transmission	flexible	solid
Y (mm)	0,1	0,04

5. Assembly / disassembly and service instructions

The gear pump can be installed on the final product in the arbitrary position. The external check of the pump must be done before its installation on the driving unit.

During handling, it is necessary to avoid damage of the flange seating face, of the spigot, of the end of driving shaft, possibly of the sealing faces at inlet and outlet.

The end of the driving shaft can be easily put into the catch cam until the pump flange face seats on the counterpart. If the pump's shaft has the spline end or claw where the permanent lubrication is not secured during operation, we recommend to lubricate it by the suitable grease on the assembly occasion.

Fix the pump to the counterpart by tightening the screws (nuts) after the pump's flange face has seated completely on the seating face of the counterpart (casing).

Remove the safety plugs of the inlet and outlet holes of all sections before connecting the pump to the hydraulic circuit. Check, whether the threads for connecting the hydraulic line are not damaged. During assembly, please, avoid the entering of impurities into the pump.

The seal on the flange face must be such arranged to prevent the oil leakage from the driving mechanism area through the pump's binder screws.

After connection, let the pump run at least 2 minutes without pressure at minimum speed and monitor whether it runs smoothly, without excessive heating. When hot oil enters the cold pump, do not load it before the whole unit is warmed up completely.

When dismantling the final product, protect the internal area by covering the connecting holes immediately.

The safety valve must be installed in the pump hydraulic circuit. The valve must be protected against incompetent manipulation. The valve is adjusted at the most on maximal permanent pump pressure. The peak pressure in the circuit must not exceed the allowed value. In case of multiple pumps, the safety valve must be installed in the circuit of each section.

The used oil quality must meet the relevant oil standard for the whole operation period and its specified cleaning must be ensured.

It must be ensured that the oil quantity in the hydraulic circuit will not drop under the value when, in the inlet branch area, the oil turbulence appears as well as the air intake and the temperature increase above the allowed limit. After pump installation into hydraulic circuit, and after any circuit dismantling, it is necessary to vent the whole system perfectly.

Hydraulic line – the intake line should have the nominal diameter specified such that at the viscosity $100 \cdot 10^{-6} \text{ m}^2 \cdot \text{s}^{-1}$ and at maximum flow, the pressure intake does not exceed the allowed values. The pressure line should have such nominal diameter that the liquid speed does not exceed $8 \text{ m} \cdot \text{s}^{-1}$.

Operation – the gear pumps do not need, during the operation, the special maintenance or service except the care of the working liquid and the regular inspections for detecting the possible leakage in joints and the checks of the pump binder screws (nuts) tightening. The oil change must be done with regard on the correct functioning of the whole hydraulic circuit. The working liquid change interval will be specified by the finalist on the base of the operation test.

At the pump assembly, with the help of two screws M5 coming through the pump, the screws tightening torque $5,5^{+0,3} \text{ Nm}$ is specified.

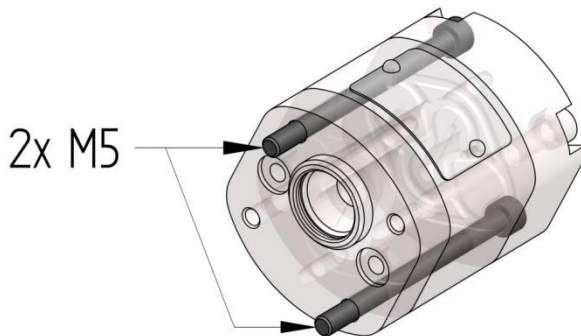

6. Warehousing warranty period - (applicable to sales representatives only)

The manufacturer provides to Jihostroj sales representatives a 1 year warranty to sale the product to an operator. This period is not included in the service life of the product and is covered by the manufacturer's warranty.

Sales representatives are required to comply with the following conditions of warehousing:

Temperature: from -20°C to +40 °C

Humidity: from 40% to 80%

7. Service warranty period

The manufacturer provides to its customers a service warranty for the product in the range of 3000 hours for 2 years from the date of sale, whichever occurs earlier.

8. Validity of the commercial warranty

The manufacturer grants the commercial warranty and guarantees the quality of the product provided the operating conditions listed in the service manual are complied with.

The customer is required to present the "Complaint report" to make a claim, containing at least the following information: Type designation, serial number, description of the defect, number of service hours.

The product that is subject to a complaint must be sent to the factory complete, clean, with blinded sockets and with flange and drive protection installed. The pump conversion or other modifications are not allowed.

The claim will be rejected and the product will be repaired at the costs of the customer unless the above conditions will be met.

The manufacturer disclaims responsibility for any damage resulting from the incorrect installation and exploitation.



Jihostroj a.s Budějovická 148, 382 32 Velešín, Czech Republic
e-mail: mailbox@jihostroj.cz, <http://www.jihostroj.com>