

juhstroj
AERO TECHNOLOGY & HYDRAULICS

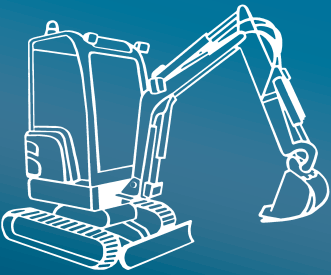

Displacement from 43 to 150 ccm
Pressure up to 280 bar
Speed from 250 to 3200 RPM

GEAR PUMPS
QHD2

TABLE OF CONTENTS

BASIC DESCRIPTION	2
PARAMETER TABLE	3
FORMULAS USED FOR CALCULATION	4
PUMP EFFICIENCIES	4
WORKING LIQUID	5
PRESSURE LOAD	5
OTHER REQUIREMENTS	6
DIRECTION OF ROTATION	6
REVERSIBLE DESIGN	6
QHD2 FLOW RATE AND POWER CURVES	7
ORDER KEY	11
COMBINATIONS OF FLANGES AND SHAFTS	12
FLANGE DESIGN	13
DRIVE SHAFTS	14
COMBINATIONS OF FLANGES AND SHAFTS	16
CATALOGUE SHETS OF QHD2 SERIES BASIC DESIGNS	18
NOTES	22

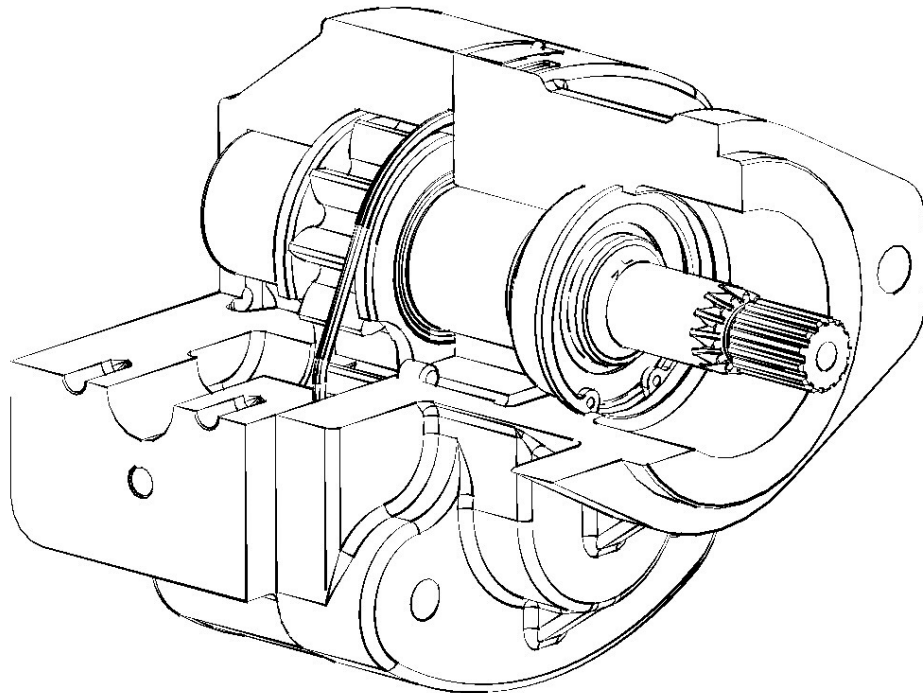

DESCRIPTION

- QHD2 series are particularly designed to be used in mobile hydraulic systems of agricultural, heavy construction and road building machines as well as in advanced hydraulic systems of material handling devices. The QHD2 series covers the range of displacements from 43 to 150 cm³/rev.
- The pumps are characterized by simple construction with hydraulic pressure balance, compact dimensions and a wide range of connection types. QHD2 pumps have a two-piece all-cast-iron construction. The basis consists of a supporting body with a blind chamber for gear wheels and a fastening flange. The body, as well as the flange are made from a high-quality grey cast iron. In the body and the flange, sliding sleeves for gear wheels are molded. Gear wheels with 12 teeth made of ultra high-strength steel, which are optimised to achieve a low noise level. The axial pump balancing is performed using sliding aluminium alloy pressure plates in which a shape sealing of balancing surface is located in grooves. For heavy duty with a weight-bearing drive shaft, the pumps can be equipped with front-end roller bearings. QHD2 construction enables the pumps to be used already at low revolutions at high pressure.
- QHD2 pumps are produced in various designs of divers clamping flanges as well as liquid inlets and outlets. These pumps comply with the standards ISO, SAE, UNI and other world-recognised standards and can be delivered in simple or multiple designs. They can also be delivered in a reversible design, with external or internal drainage.

BASIC PARTS OF PUMP

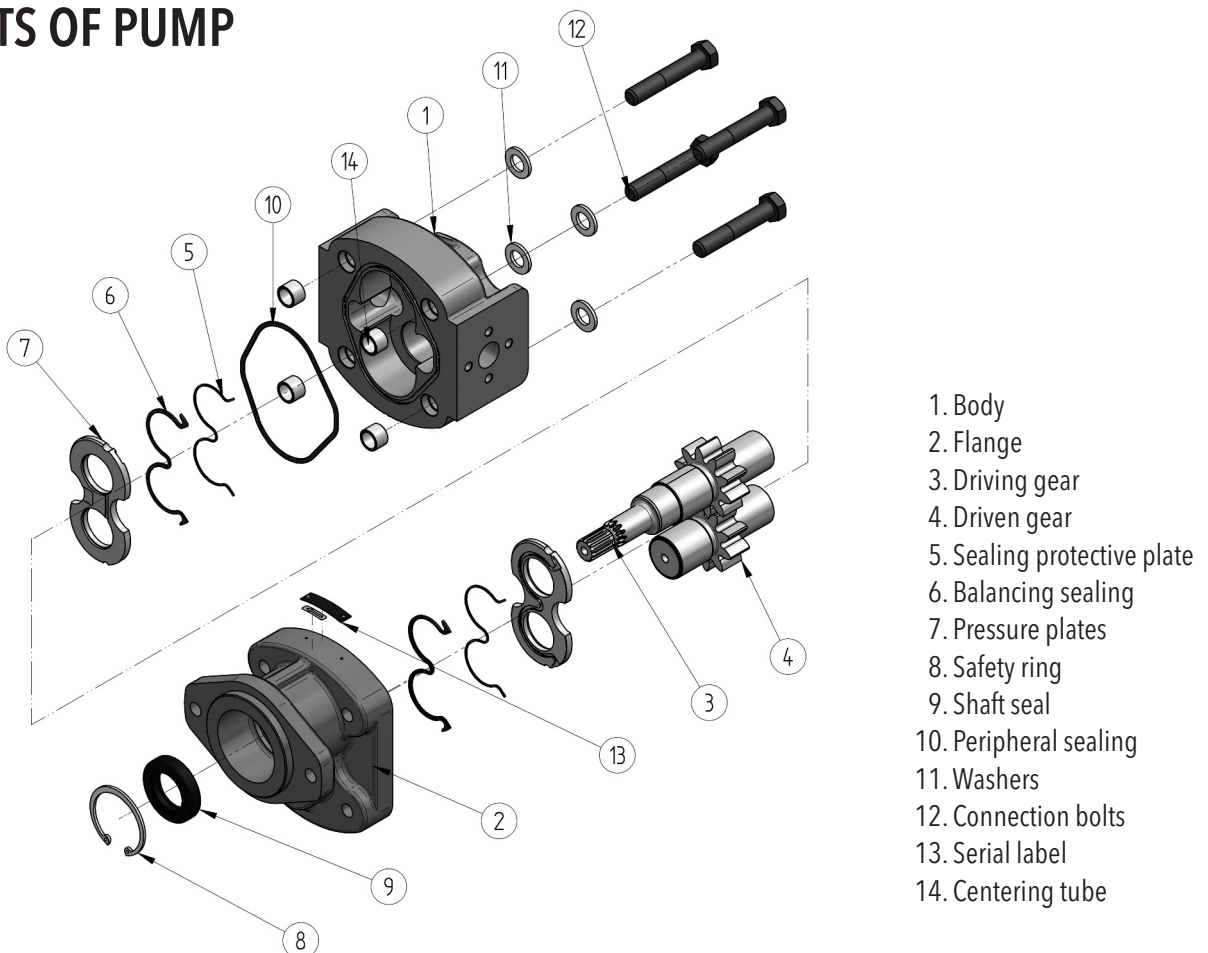

1. Body
2. Flange
3. Driving gear
4. Driven gear
5. Sealing protective plate
6. Balancing sealing
7. Pressure plates
8. Safety ring
9. Shaft seal
10. Peripheral sealing
11. Washers
12. Connection bolts
13. Serial label
14. Centering tube

PARAMETER TABLE

Nominal Size Parameters		Sym.	Unit	QHD2 43	QHD2 51	QHD2 56	QHD2 61	QHD2 71	QHD2 82
Actual displacement		V_g	[cm ³]	43.57	51.81	56.52	61.23	71.83	82.43
Rotation speed	nominal	n_n	[min ⁻¹]	1500	1500	1500	1500	1500	1500
	minimum	n_{min}	[min ⁻¹]	400	400	400	400	400	400
	maximum	n_{max}	[min ⁻¹]	3200	3200	3200	3200	3200	3000
Pressure at inlet*	minimum	p_{1min}	[bar]	-0,3	-0,3	-0,3	-0,3	-0,3	-0,3
	maximum	p_{1max}	[bar]	0,5	0,5	0,5	0,5	0,5	0,5
Pressure at outlet**	max. continuous	p_{2n}	[bar]	280	280	280	270	260	260
	maximum	p_{2max}	[bar]	300	300	300	290	280	280
	peak	p_3	[bar]	310	310	310	300	290	290
Nominal flow rate (min.) at n_n and p_{2n}		Q_n	[dm ³ .min ⁻¹]	60.4	69.9	76.3	82.7	99.1	116.2
Maximum flow rate at n_{max} a p_{2max}		Q_{max}	[dm ³ .min ⁻¹]	136.6	162.5	177.2	192.0	225.3	242.3
Nominal input power (max.) at n_n and p_{2n}		P_n	[kW]	36.1	44.8	48.8	51.0	56.4	63.3
Maximum input power at n_{max} a p_{2max}		P_{max}	[kW]	79.0	94.0	102.5	107.4	121.6	130.8
Weight		m	[kg]	-	-	-	-	-	-

Nominal Size Parameters		Sym.	Unit	QHD2 90	QHD2 100	QHD2 110	QHD2 125	QHD2 150
Actual displacement		V_g	[cm ³]	90.67	100.09	110.69	125.99	150.72
Rotation speed	nominal	n_n	[min ⁻¹]	1500	1500	1500	1500	1500
	minimum	n_{min}	[min ⁻¹]	400	350	350	250	250
	maximum	n_{max}	[min ⁻¹]	2800	2700	2600	2400	2000
Pressure at inlet*	minimum	p_{1min}	[bar]	-0.3	-0.3	-0.3	-0.3	-0.3
	maximum	p_{1max}	[bar]	0.5	0.5	0.5	0.5	0.5
Pressure at outlet**	max. continuous	p_{2n}	[bar]	240	230	210	190	170
	maximum	p_{2max}	[bar]	260	250	230	210	190
	peak	p_3	[bar]	270	260	240	220	200
Nominal flow rate (min.) at n_n and p_{2n}		Q_n	[dm ³ .min ⁻¹]	127.8	141.1	156.1	177.6	212.5
Maximum flow rate at n_{max} a p_{2max}		Q_{max}	[dm ³ .min ⁻¹]	248.8	264.8	282.0	296.3	295.4
Nominal input power (max.) at n_n and p_{2n}		P_n	[kW]	64.3	68.0	68.7	70.7	75.7
Maximum input power at n_{max} a p_{2max}		P_{max}	[kW]	124.7	127.7	125.1	120.0	108.2
Weight		m	[kg]	-	-	-	-	-

* Inlet pressure in the reversible design can be up to $p_1 = p_{2n} - 70$ bar max. External drainage must be used in case of the reversible design.

** Outlet pressure in the reversible design is **10% lower** than shown in the table (depending on operating conditions - it is necessary to consult with the manufacturer).

FORMULAS USED FOR CALCULATION

Flow rate
Q

$$Q = \frac{V_g \cdot n}{1000} \cdot \eta_v \quad [\text{dm}^3 \cdot \text{min}^{-1}]$$

V_g [cm³] pump displacement
 n [min⁻¹] rotation speed
 η_v [-] volumetric efficiency

Displacement
V_g

$$V_g = \frac{Q \cdot 1000}{n \cdot \eta_v} \quad [\text{cm}^3]$$

Torque
M_k

$$M_k = \frac{V_g \cdot p}{20 \cdot \pi \cdot \eta_m} \quad [\text{Nm}]$$

p [bar] required pressure at outlet
 η_m [-] mechanical efficiency

Input power
P

$$P = \frac{V_g \cdot n \cdot p}{600 \cdot 1000 \cdot \eta_t} \quad [\text{kW}]$$

η_t [-] total efficiency

PUMP EFFICIENCIES

Volumetric efficiency

η_v

It determines the amount of flow losses. Its value is $\eta_v = 0,92 \div 0,98$ (depending on rotation speed, viscosity of working liquid and outlet pressure). It can be expressed as follows:

$$\eta_v = \frac{Q_{act.}}{Q_{theor}} \quad [-]$$

$Q_{act.}$ [dm³ · min⁻¹] actual flow rate
 Q_{theor} [dm³ · min⁻¹] theoretical flow rate

Mechanical efficiency

η_m

It determines mechanical losses. Its value is about $\eta_m = 0,85$. It can be expressed as follows:

$$\eta_m = \frac{M_{theor}}{M_{act.}} \quad [-]$$

$M_{act.}$ [Nm] actual torque
 M_{theor} [Nm] theoretical torque

Total efficiency

η_t

It is defined as product of η_v and η_m and determines difference between theoretical and actual required input power:

$$\eta_t = \eta_v \cdot \eta_m = \frac{P_{theor}}{P_{act.}} \quad [-]$$

$P_{act.}$ [kW] actual input power
 P_{theor} [kW] theoretical input power

WORKING LIQUID

- Mineral oils for hydraulic drives
- Hydraulic liquids based on plant oils suitable for hydraulic drives

Liquid temperature

- $t = -20 \div +80$ [°C]
when used with FKM (Viton) seal up to 120 [°C]

Cinematic viscosity

- Recommended (during continuous operation): $\nu = 20 \div 80 \cdot 10^{-6}$ [m² · s⁻¹]
- Maximum (cold starting, at viscosity >1000, operating pressure <10 bar is permissible, speed <1500·min⁻¹): $\nu = 1200 \cdot 10^{-6}$ [m² · s⁻¹]
- Minimum (operating mode at $10 \cdot 10^{-6}$ up $20 \cdot 10^{-6}$ should be consulted with manufacturer): $\nu = 10 \cdot 10^{-6}$ [m² · s⁻¹]

Filtration coefficient β_{α}

$\beta_{25} 75 \geq$ (for pressure $p_2 < 200$ bar)
 $\beta_{10} 75 \geq$ (for pressure $p_2 > 200$ bar)

Liquid contamination class according to ISO 4406

21/18/15 (for pressure $p_2 < 200$ bar)
20/17/14 (for pressure $p_2 > 200$ bar)

Liquid contamination class according to NAS 1638

10 (for pressure $p_2 < 200$ bar)
8 (for pressure $p_2 > 200$ bar)

PRESSURE LOAD

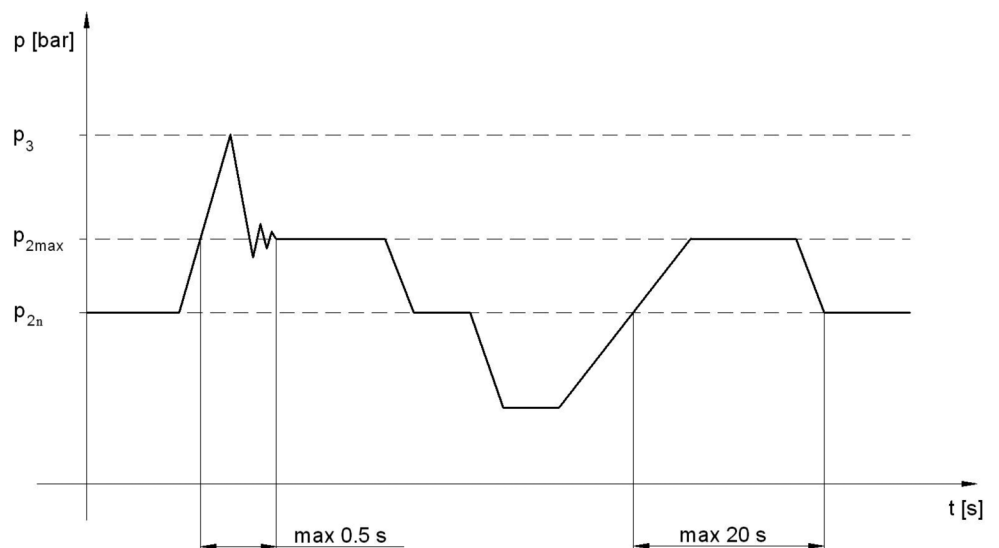

- p_{2n} **max. contin. pressure** Max. working pressure, at which the pump can be operated without time limitation.
- p_{2max} **max. pressure** Maximum pressure permissible for a short time, max. 20s.
- p_3 **peak pressure** Short-time pressure (fractions of a second) arising in case of a sudden change of the operating mode; any excess of this pressure during operation is impermissible.

OTHER REQUIREMENTS

- A driving device must not generate an axial or a radial load of the pump shaft, unless this is exclusively permitted for the pump with a front-end bearing.
- All the matters affecting technical parameters and properties of the pump are given in respective operating manuals, technical specifications and test specifications of the manufacturer.

DIRECTION OF ROTATION

- Determine direction of rotation by looking at the drive shaft. The pump can only be used in the specified direction of rotation.

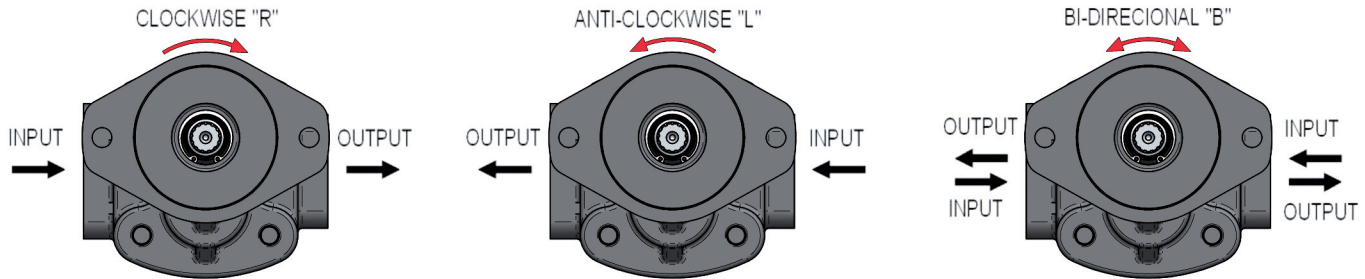

REVERSIBLE DESIGN

- The pumps with the possibility of bidirectional rotation have a different internal arrangement requiring drainage. Two types are used - internal and external. The internal drainage is always interconnected with the outlet by means of valves. The external drainage is solved by an orifice located in the cover opposite the driven gear.

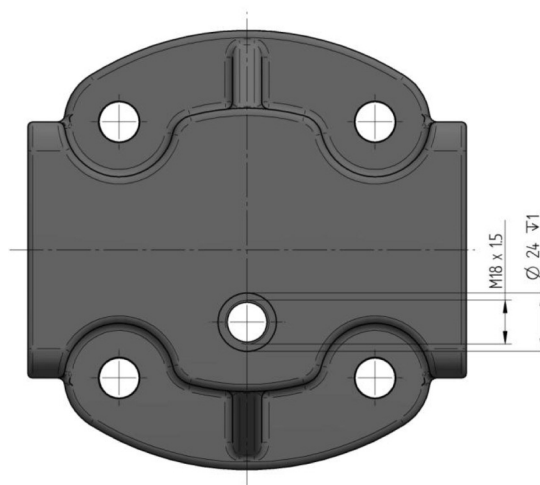

QHD2 FLOW RATE AND POWER CURVES

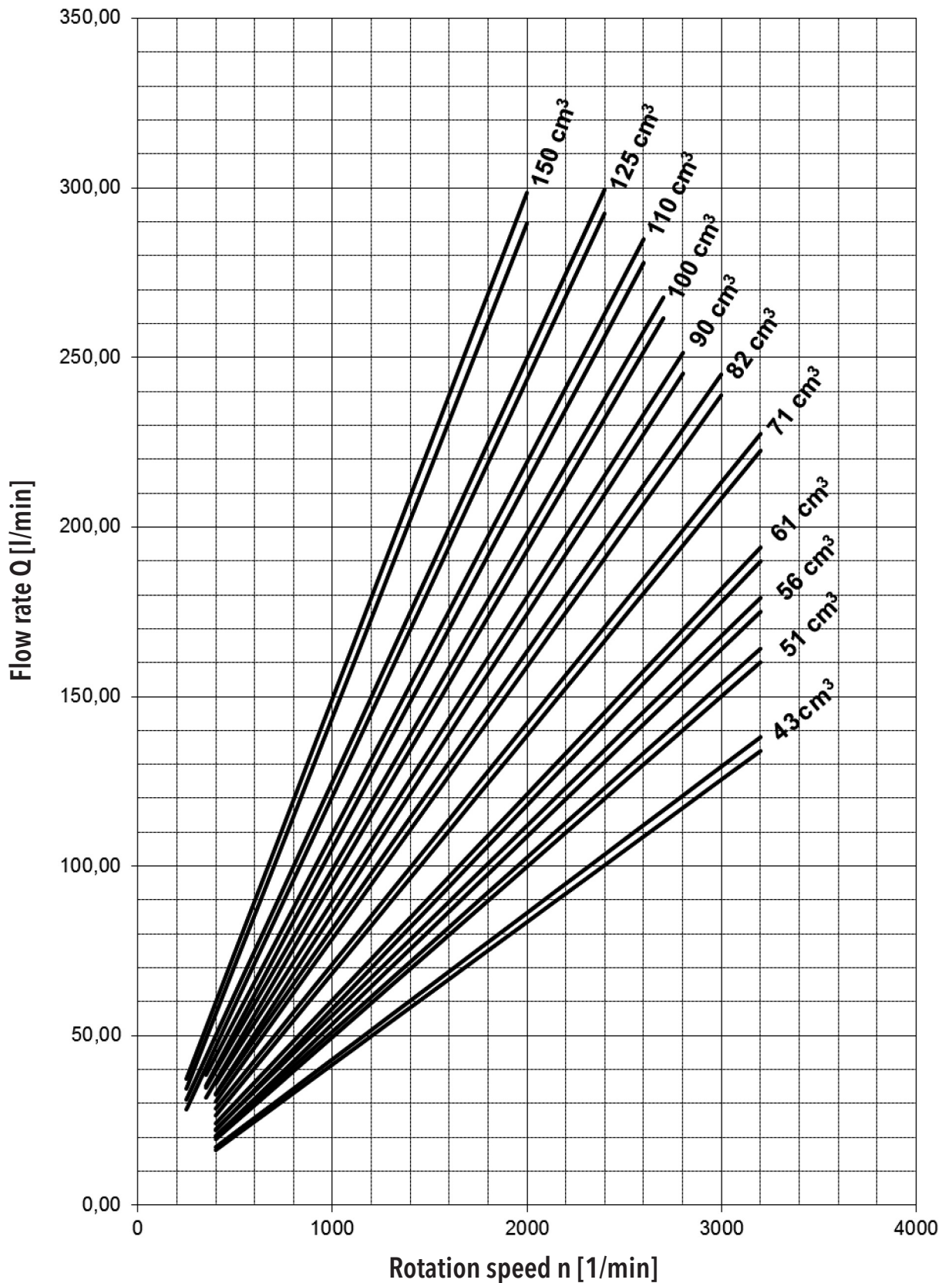

Above curves apply to ISO Vg 46 oil at temperature $t = 45^{\circ}\text{C}$.

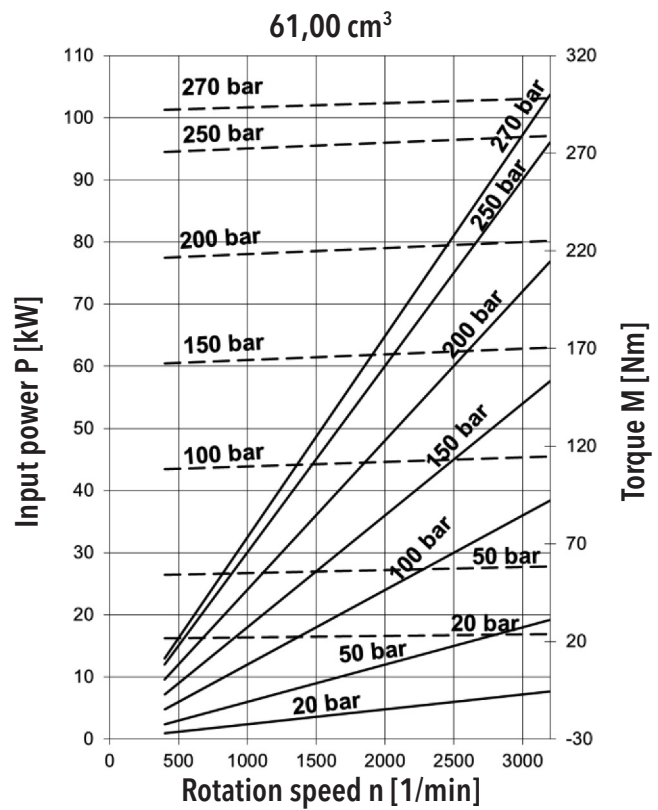
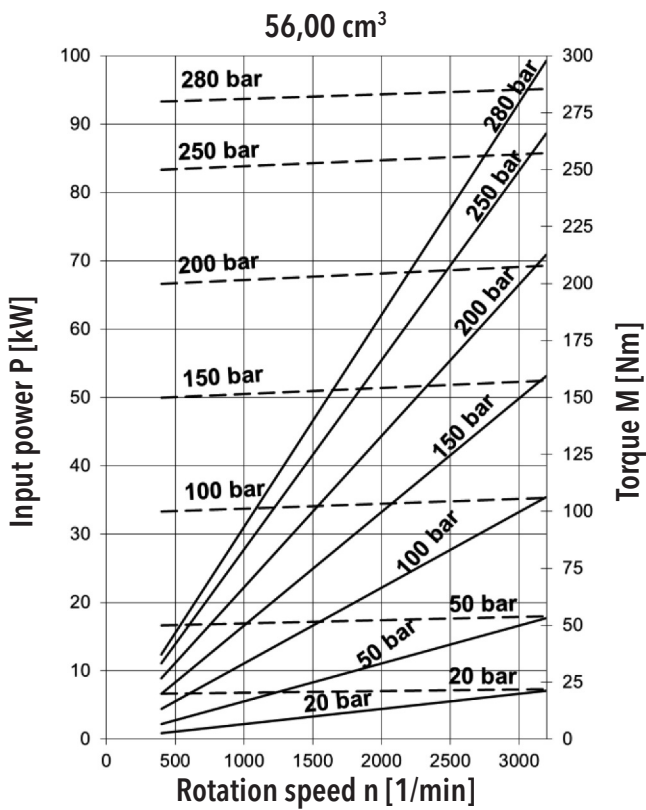
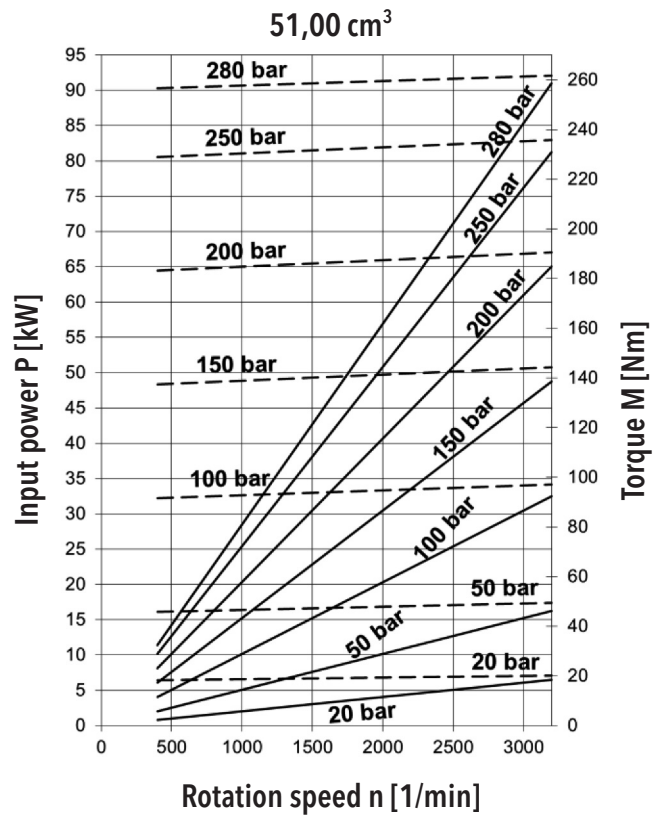
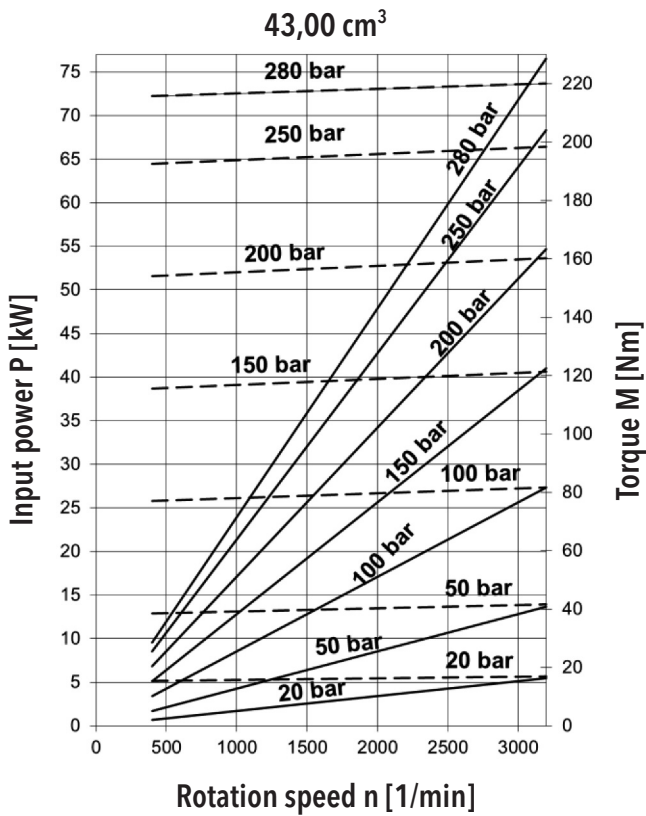

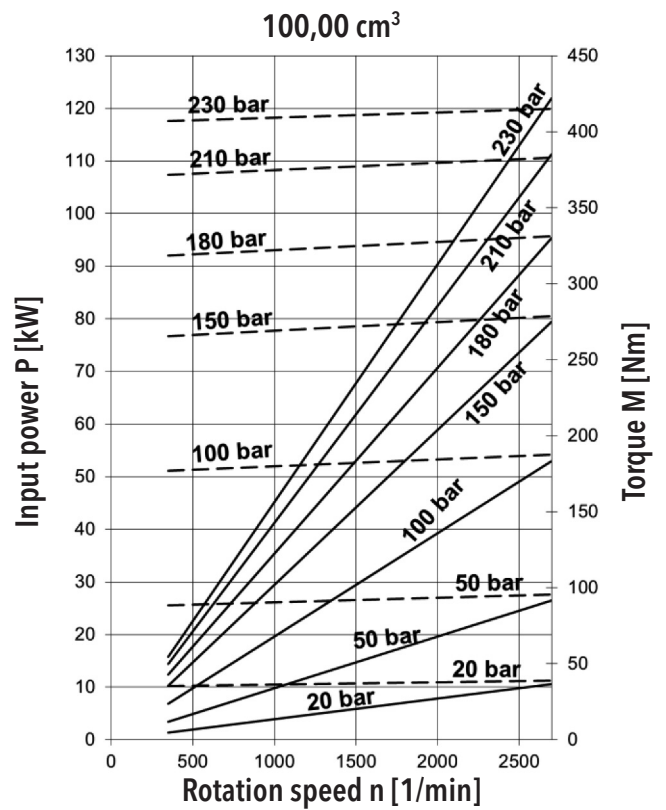
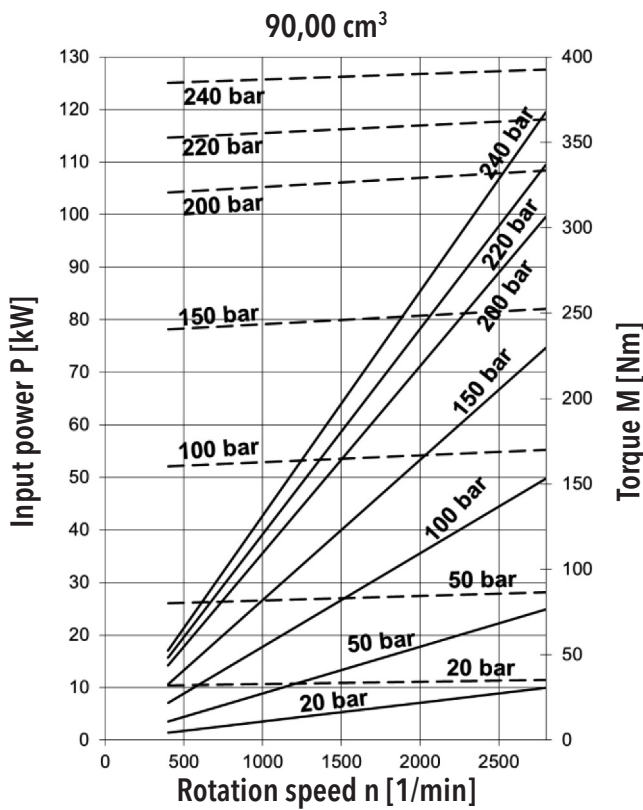
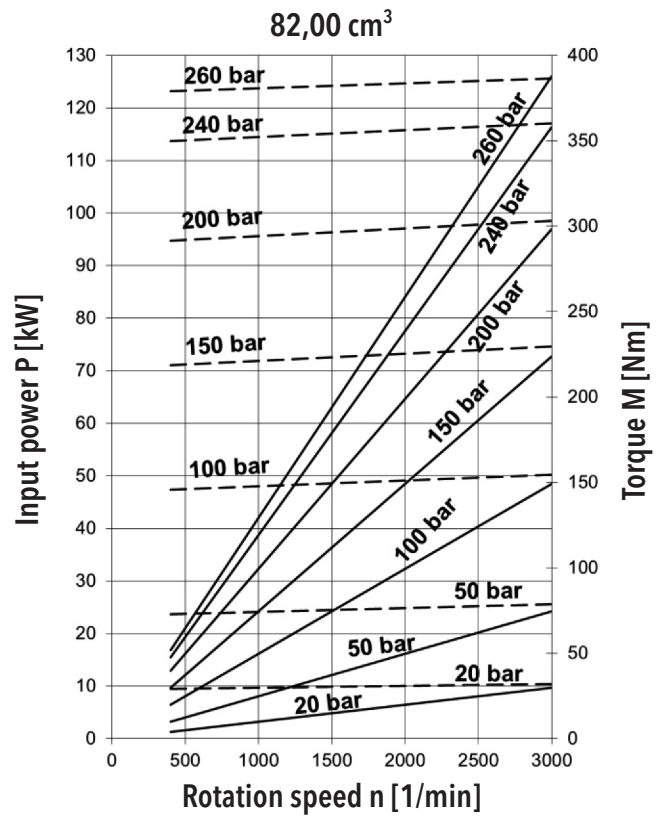
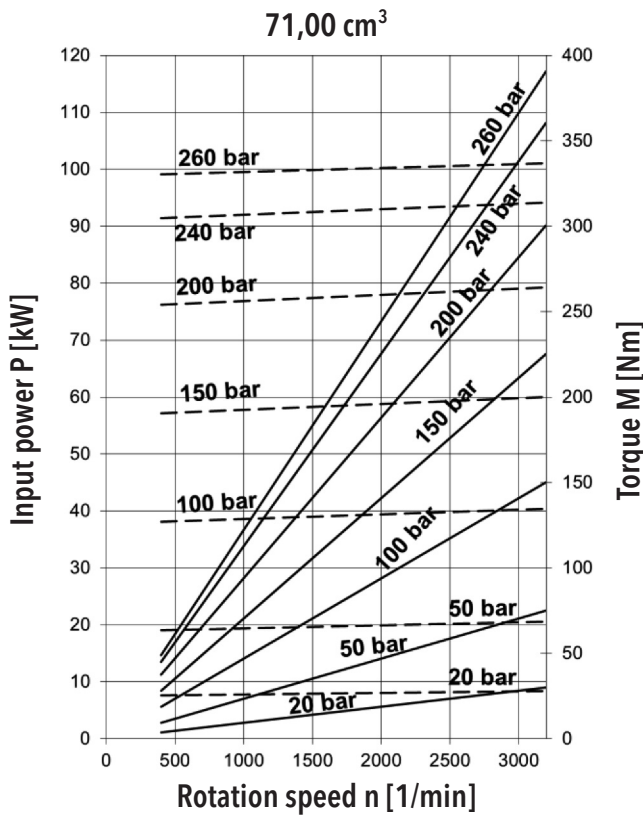

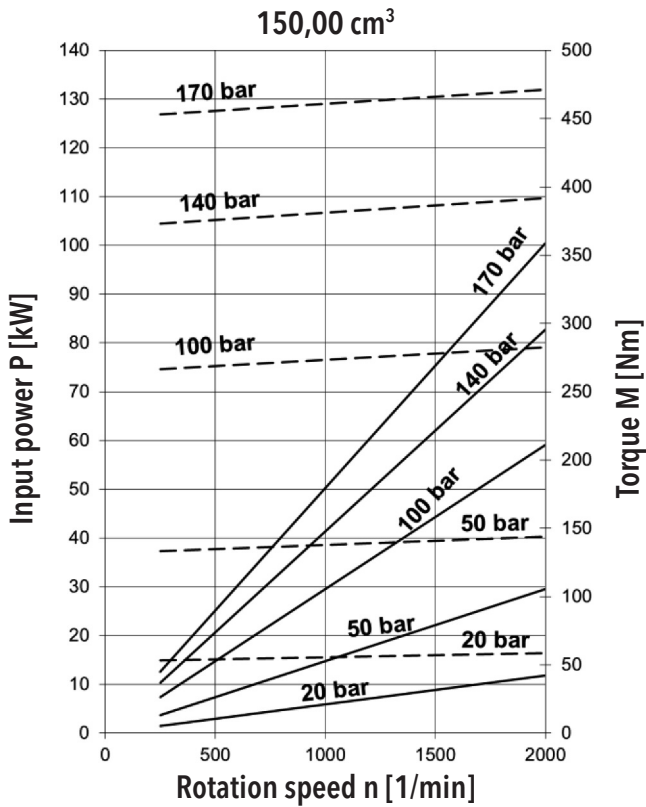
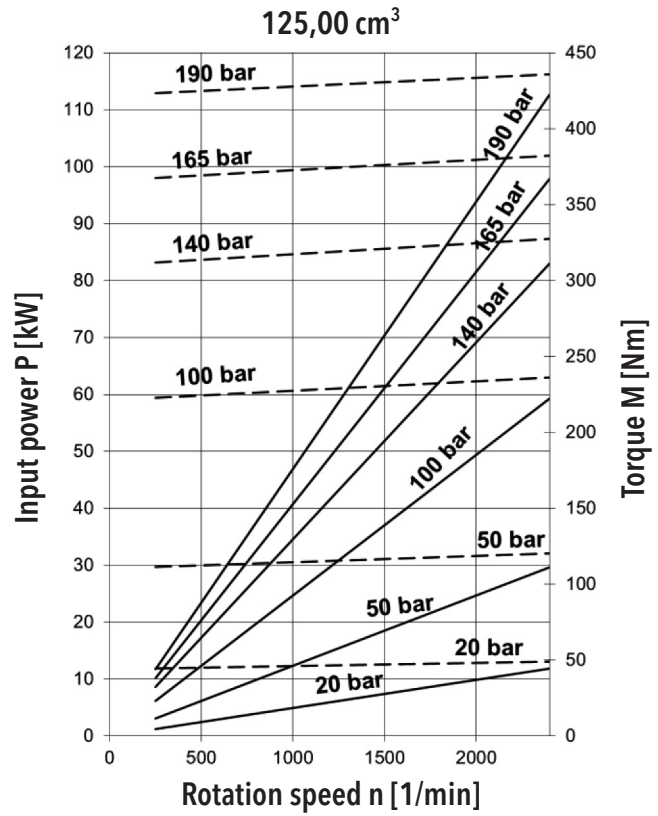
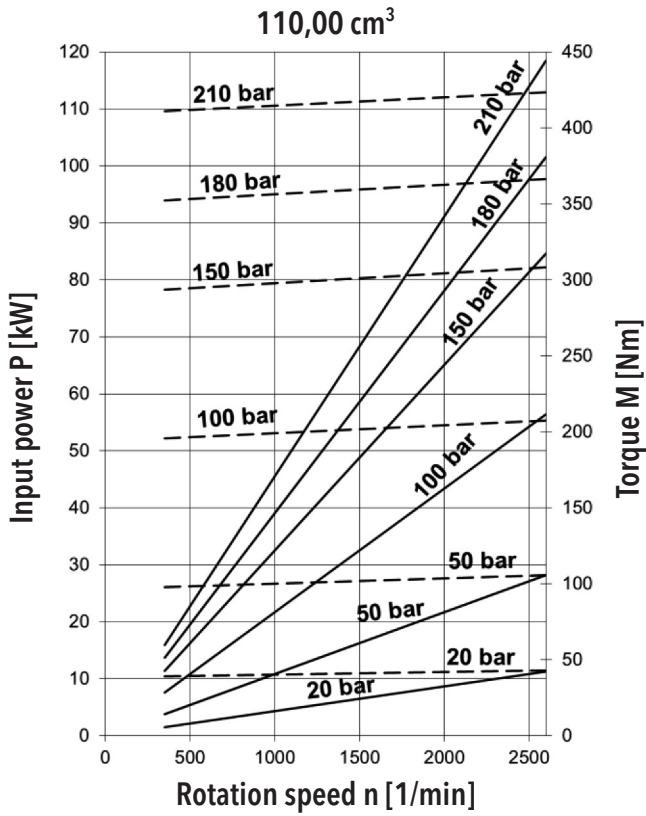







ORDER KEY



QHD2 - 56 R - S03 D13 - S E05 E04 - N . 001



Code	Type
QHD2	QHD2 Series Gear Pump

Code	Displacement [cm ³]
43	43,57
51	51,81
56	56,52
61	61,23
71	71,83
82	82,43
90	90,67
100	100,09
110	110,69
125	125,99
150	150,72
XX	Other displacements on request







Code	Direction of rotation
R	Clockwise
L	Anti-clockwise
B	Bi-directional

Code	Flange design
R15	 squared flange, centre ring Ø90, Spacing screw 155 x 155
S03	 SAE B - 2 apertures
S04	 SAE C - 2 apertures
S06	 SAE C - 2 + 4 apertures
I02	 ISO, centre ring Ø80
F03	 squared flange, centre ring Ø50,8 Ø125, Spacing screw Ø160
Z	Special desing

Code	Location of inlets and outlets
S	 Side (in the body)
R	 Axial (in the cover)
C	 Combination

Code	Seal material
N	 NBR
V	 FKM (VITON)
H	 HNBR

Code	Liquid inlet and outlet connection shape
M08	Thread M 27x1,5
M09	Thread M 27x2
M11	Thread M 33x1,5
M12	Thread M 33x2
M15	Thread M 48x2
G05	Thread BSP G1"
G06	Thread BSP G1 1/4
G07	Thread BSP G1 1/2
G09	Thread BSP G2"
U07	Thread 1-5/16-12 UN
U08	Thread 1-5/8-12 UN
U09	Thread 1-7/8-12 UN
U10	Thread 2-1/2-12 UN
H08	Fitting Ø20;4xM8;Ø40
H09	Fitting Ø18;4xM8;Ø55
H10	Fitting Ø25;4xM8;Ø55
A03	Fitting SAE (SSS) 1"
A04	Fitting SAE (SSS) 1" 1/4
A05	Fitting SAE (SSS) 1" 1/2
A06	Fitting SAE (SSS) 2"
E03	Fitting SAE (SSM) 1"
E04	Fitting SAE (SSM) 1" 1/4
E05	Fitting SAE (SSM) 1" 1/2
E06	Fitting SAE (SSM) 2"
K03	Fitting Ø18;4xM8 / Ø40
K04	Fitting Ø26;4xM10/Ø51
K05	Fitting Ø18;4xM8 / Ø55
K06	Fitting Ø25;4xM8 / Ø55
S04	Fitting Ø46;4xM12 - 78x78
S05	Fitting Ø22;4xM10 - 48x48
S06	Fitting Ø30;4xM10 - 48x48
Z	Special desing

Code	Drive shaft desing
D13	Spline SAE B 13T
D14	 Spline SAE C 14T
D15	Spline SAE B 15T
D18	 Spline DIN 5462 A8 x 32 x 36 x 6
D19	 Spline ČSN 28 x 1,5
D25	 Spline ČSN 014942 D-6 x 28 x 34e9 x 7
D26	 Spline ČSN 38 x 1,5
D27	 Spline DIN 5480 WA 35 x 2 x 16 x 9g
V17	Cylindric SAE B, Ø22,22 Key 6,4 x 6,4 x 25,4
V18	 Cylindric SAE BB, Ø25,4 Key 6,4 x 6,4 x 31,8
V19	Cylindric SAE C, Ø31,7 Key 7,9 x 7,9 x 31,8
Z	Special desing

An example of designation for the QHD2 clockwise pump with displacement of 56 cm³, flange with centre ring Ø 101,6, Involute spline 25x1,5, Flanged fittings according to SAE, metric thread, standard NBR: **QHD2 - 56 R - S03D13 - SE05E04 - N**

Note: In case of combination inlets, with the code „C” is respected following sequence of inlets and outlets:

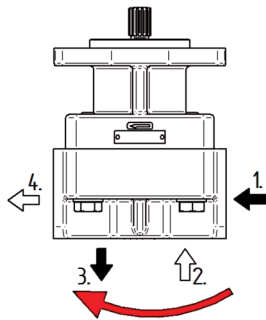

For clockwise and reverse gear pump,
in direction clockwise

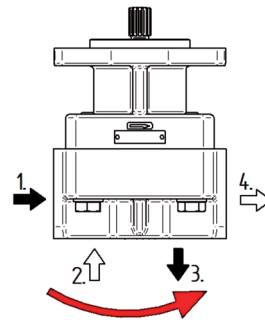

For anti-clockwise gear pump,
in direction anti-clockwise

For. ex....: QHD2-43B-S03D13-CG05 G05 G04 G04 -N
1. 2. 3. 4.

COMBINATIONS OF FLANGES AND SHAFTS

		FLANGE DESIGN						
		R14	R15	S03	S04	S06	I02	F03
DRIVE SHAFT	D13				●			
	D14				●	●		
	D15				●	○	○	
	D18						●	
	D19		●					
	D25			●				
	D26		●					
	D27							●
	V17				●			
	V18				●	○	○	
	V19					●	●	

FLANGES DESIGN

R14:

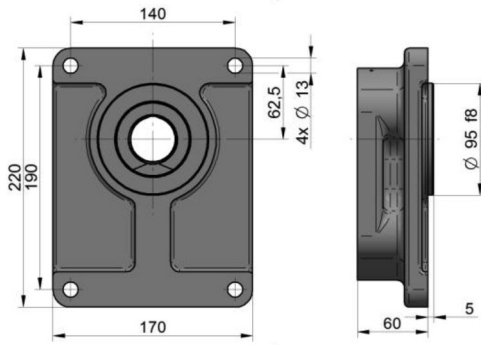

R15:

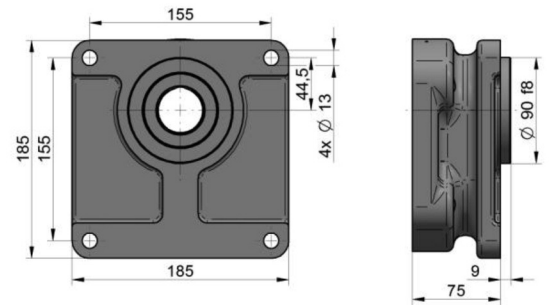

S03:

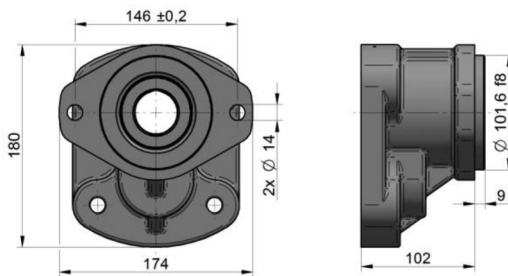

S04:

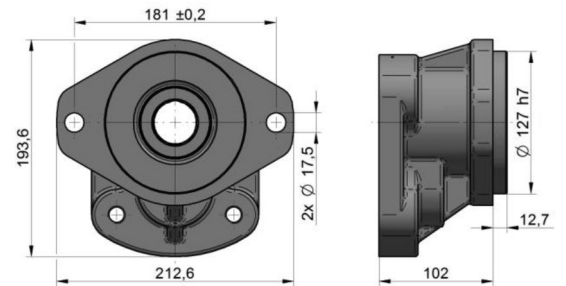

S06:

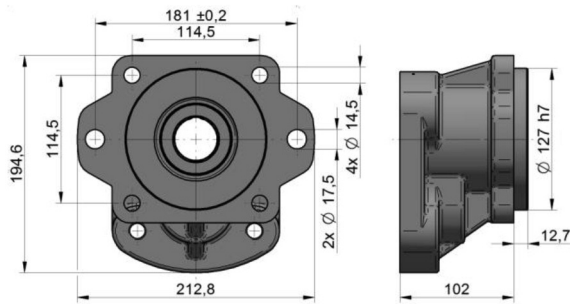

I01:

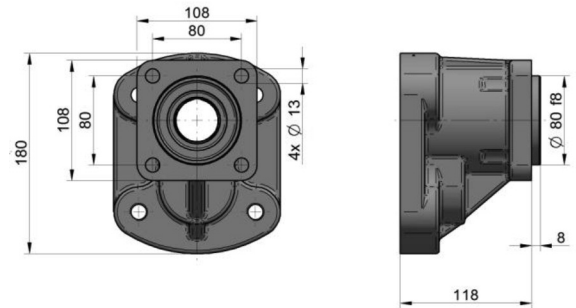

F03:

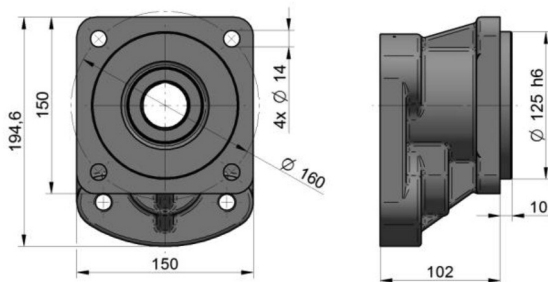

DRIVE SHAFTS

D13:

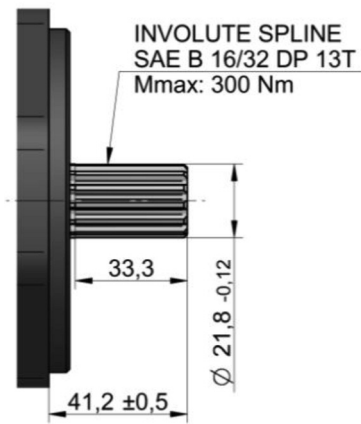

D14:

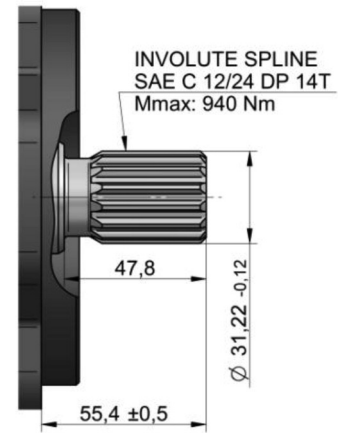

D15:

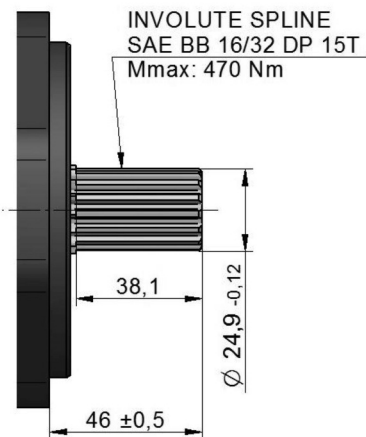

D18:

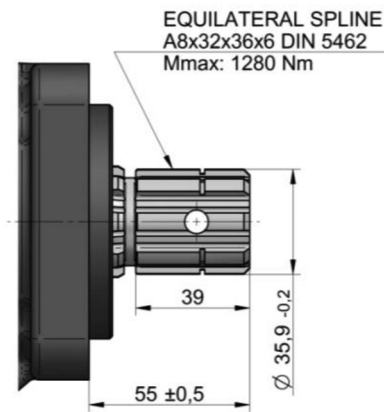

D19:

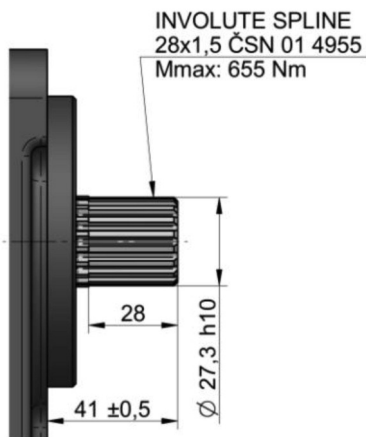

D25:

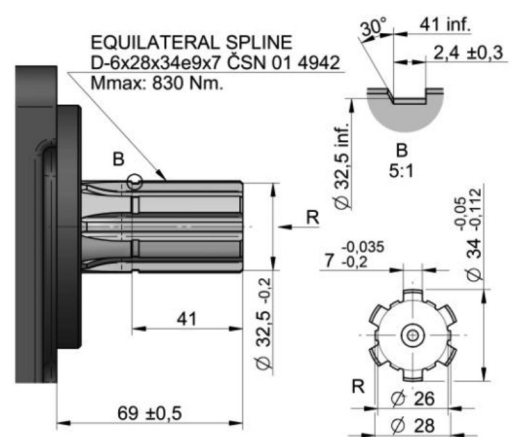

D26:

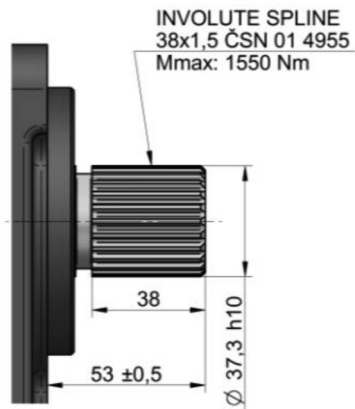

D27:

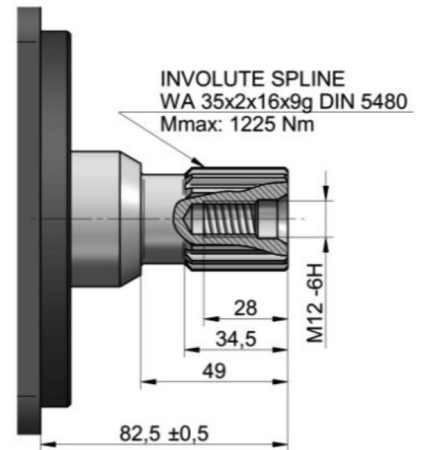

V17:

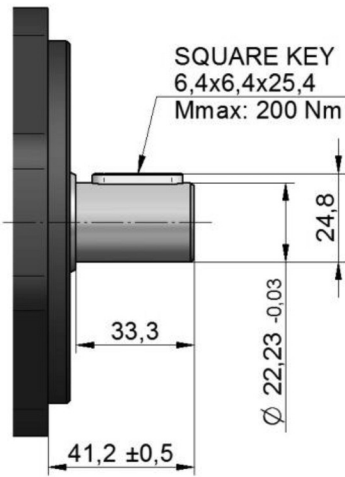

V18:

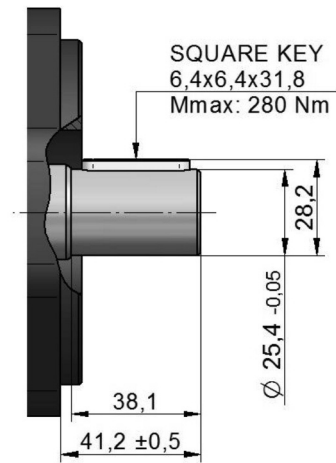

V19:

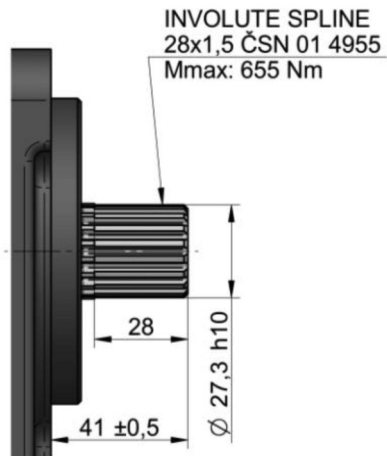

LIQUID INLET AND OUTLET CONNECTION

Metric thread according to ISO 6149

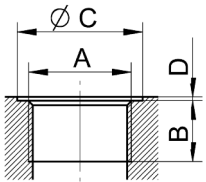

Displacement [cm ³]	Code	Inlet				Code	Outlet			
		A	B	C	D		A	B	C	D
43 - 51	M11	M 33x1.5	18	40	1	M08	M 27x1.5	16	33	1
43 - 51	M12	M 33x2	18	40	1	M09	M 27x2	16	33	1
51 - 150	M15	M 48x2	22	56	1	M12	M 33x2	18	40	1

BSPP pipe thread according to ISO 228-1

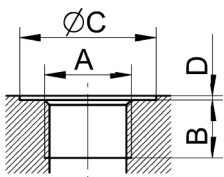

Displacement [cm ³]	Code	Inlet				Code	Outlet			
		A	B	C	D		A	B	C	D
43 - 71	G06	G 1 1/4"	24	58	1	G05	G 1"	18	45	1
71 - 100	G07	G 1 1/2"	26	64	1	G06	G 1 1/4"	24	58	1
100 - 150	G09	G 2"	32	78	1	G07	G 1 1/2"	26	64	1

UNF thread according to SAE

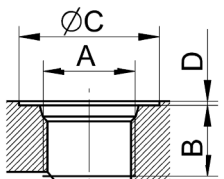

Displacement [cm ³]	Code	Inlet				Code	Outlet			
		A	B	C	D		A	B	C	D
43 - 71	U08	1-5/8-12UN	19	58	1	U07	1-5/16-12UN	19	49	1
51 - 80	U08	1-5/8-12UN	19	58	1	U07	1-5/16-12UN	19	49	1
80 - 150	U09	1-7/8-12UN	19	65	1	U08	1-5/8-12UN	19	58	1

Flanged fittings according to DIN 8901/8902

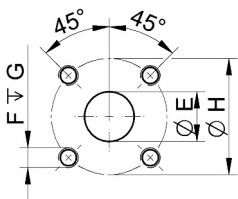

Displacement [cm ³]	Code	Inlet				Code	Outlet			
		E	F	G	H		E	F	G	H
43 - 51	H10	25	M8	16	55	H09	18	M8	16	55

Note: Applicable only as side inputs

Flanged fittings according to SAE, metric thread

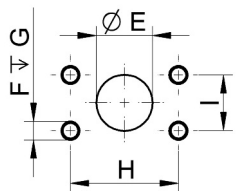

Displacement [cm ³]	Code	Inlet					Code	Outlet				
		E	F	G	H	I		E	F	G	H	I
43-51	E04	30.5	M10	22	58.7	30.2	E03	25.4	M10	22	52.4	26.2
51-71	E05	39.3	M12	27	69.8	35.7	E04	30.5	M10	22	58.7	30.2
51-82	E05	39.3	M12	27	69.8	35.7	E04	30.5	M10	22	58.7	30.2
82-150	E06	51.0	M12	27	77.8	42.9	E05	39.3	M12	27	69.8	35.7

Note: Applicable only as side inputs

Flanged fittings according to SAE, UNC thread

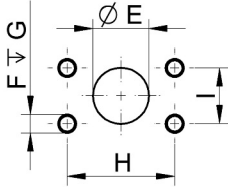

Displacement [cm ³]	Code	Inlet					Code	Outlet				
		E	F	G	H	I		E	F	G	H	I
43-51	A04	30.5	7/16-14 UNC-2B	28.5	58.7	30.2	A03	25.4	3/8-16 UNC-2B		52.4	26.2
51-71	A05	39.3	1/2-13 UNC-2B	27.0	69.8	35.7	A04	30.5	7/16-14 UNC-2B	29	58.7	30.2
51-82	A05	39.3	1/2-13 UNC-2B	27.0	69.8	35.7	A04	30.5	7/16-14 UNC-2B	29	58.7	30.2
82-150	A06	51.0	1/2-13 UNC-2B	27.0	77.8	42.9	A05	39.3	1/2-13 UNC-2B	27	69.8	35.7

Note: Applicable only as side inputs

Flanged fittings - „cross“

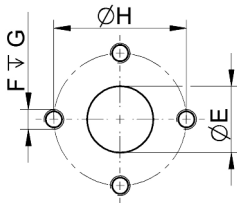

Displacement [cm ³]	Code	Inlet				Code	Outlet			
		E	F	G	H		E	F	G	H
43-51	K04	26	M10	18	51	K03	18	M8	18	40
43-51	K06	25	M8	16	55	K05	18	M8	16	55

Note: Applicable only as side inputs

Flanged fittings - „square“

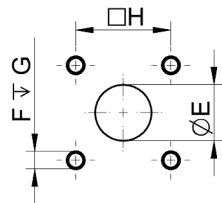

Displacement [cm ³]	Code	Inlet				Code	Outlet			
		E	F	G	H		E	F	G	H
43-51	S06	30	M10	22	48	S05	22	M10	22	48
51-150	S04	46	M12	24	78	S04	46	M12	24	78

Note: S04 - Applicable only as side inputs
S05, S06 - Applicable as axial inputs

Drains:

Displacement [cm ³]	Code	Outlet			
		A	B	C	D
all	M05	M 18 x 1.5	14	24	1
all	M07	M 22 x 1.5	14	28	1
all	G03	G 1/2"	14	33	1

CATALOGUE SHETS OF QHD2 SERIES BASIC DESIGNS

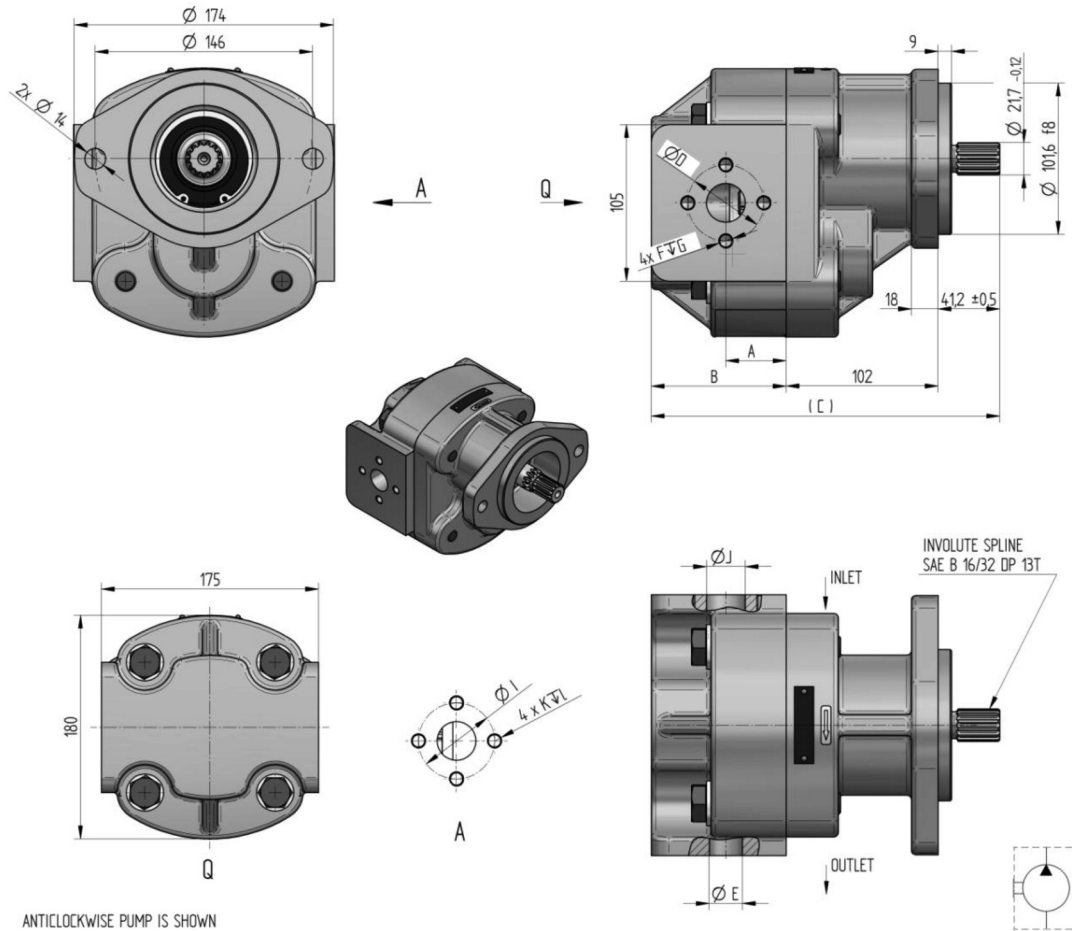

ANTICLOCKWISE PUMP IS SHOWN

Order key	purch. code	direct. of rot.	displacement [cm ³ /1]	nom. press. [bar]	speed MIN. [min ⁻¹]	speed MAX. [min ⁻¹]	dimension													
							A [mm]	B [mm]	C [mm]	$\varnothing D$ [mm]	$\varnothing E$ [mm]	F [mm]	G [mm]	$\varnothing I$ [mm]	$\varnothing J$ [mm]	K [mm]	L [mm]			
QHD2-150R-S03D13-		R	150	170	250	2000	78,0	130,5	273,7											
QHD2-150L-S03D13-		L																		
QHD2-125R-S03D13-		R	125	190	250	2400	67,5	120,0	263,2											
QHD2-125L-S03D13-		L																		
QHD2-110R-S03D13-		R	110	210	350	2600	61,0	113,5	256,7											
QHD2-110L-S03D13-		L																		
QHD2-100R-S03D13-		R	100	230	350	2700	56,5	109,0	252,2											
QHD2-100L-S03D13-		L																		
QHD2-90R-S03D13-		R	90	240	400	2800	52,5	105,0	248,2											
QHD2-90L-S03D13-		L																		
QHD2-82R-S03D13-		R	82	260	400	3000	50,8	101,5	244,7											
QHD2-82L-S03D13-		L																		
QHD2-71R-S03D13-		R	71	260	400	3200	48,5	97,0	240,2											
QHD2-71L-S03D13-		L																		
QHD2-61R-S03D13-		R	61	270	400	3200	46,3	92,5	235,7											
QHD2-61L-S03D13-		L																		
QHD2-56R-S03D13-K04K04-N		R	56	280	400	3200	40,5	90,5	233,7	51	26	M10	16	51	26	M10	16			
QHD2-56L-S03D13-K04K04-N	188 9806	L																		
QHD2-51R-S03D13-		R	51	280	400	3200	38,5	88,5	231,7											
QHD2-51L-S03D13-		L																		
QHD2-43R-S03D13-		R	43	280	400	3200	32,5	85,0	228,2											
QHD2-43L-S03D13-		L																		

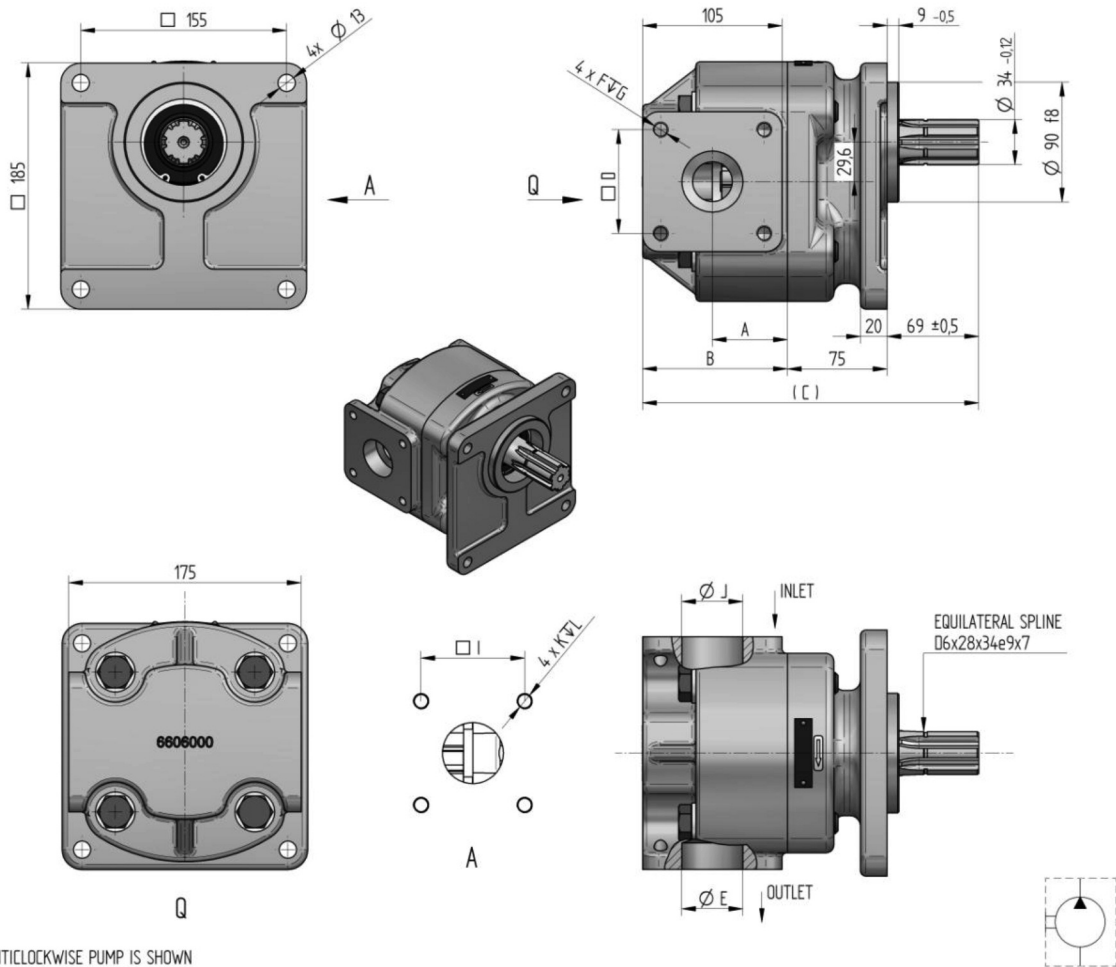

ANTICLOCKWISE PUMP IS SHOWN

Order key	purch. code	direct. of rot.	displacement [cm ³ /1]	nom. press. [bar]	speed MIN. [min ⁻¹]	speed MAX. [min ⁻¹]	dimension										
							A [mm]	B [mm]	C [mm]	ØD [mm]	ØE [mm]	F [mm]	G [mm]	ØI [mm]	ØJ [mm]	K [mm]	L [mm]
QHD2-150R- R15D25-		R	150	170	250	2000	78,0	130,5	274,0								
QHD2-150L- R15D25-		L															
QHD2-125R- R15D25-		R	125	190	250	2400	67,5	120,0	264,0								
QHD2-125L- R15D25-		L															
QHD2-110R- R15D25-		R	110	210	350	2600	61,0	113,5	257,5								
QHD2-110L- R15D25-		L															
QHD2-100R- R15D25-SS04S04N		R	100	230	350	2700	56,5	109,0	253,0	78	46	M12	24	78	46	M12	24
QHD2-100L- R15D25-SS04S04N		L															
QHD2-90R- R15D25-		R	90	240	400	2800	52,5	105,0	249,0								
QHD2-90L- R15D25-		L															
QHD2-82R- R15D25-		R	82	260	400	3000	50,8	101,5	243,9								
QHD2-82L- R15D25-		L															
QHD2-71R- R15D25-		R	71	260	400	3200	48,5	97,0	241,0								
QHD2-71L- R15D25-		L															
QHD2-61R- R15D25-		R	61	270	400	3200	46,3	92,5	236,5								
QHD2-61L- R15D25-		L															
QHD2-56R- R15D25-		R	56	280	400	3200	40,5	90,5	234,5								
QHD2-56L- R15D25-		L															
QHD2-51R- R15D25-		R	51	280	400	3200	36,0	88,5	232,5								
QHD2-51L- R15D25-		L															
QHD2-43R- R15D25-		R	43	280	400	3200	32,5	85,0	229,0								
QHD2-43L- R15D25-		L															

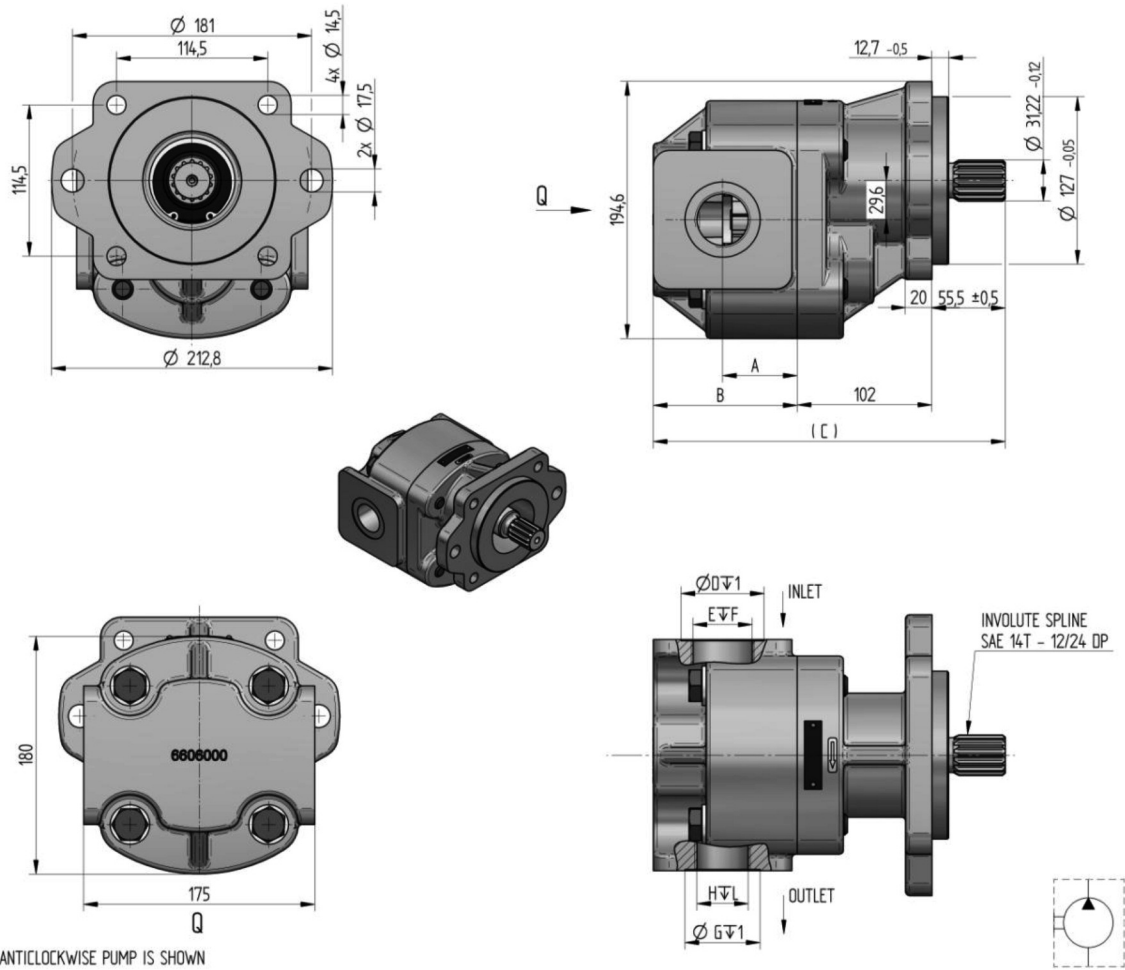

ANTICLOCKWISE PUMP IS SHOWN

Order key	purch. code	direct. of rot.	displacement [cm ³ /1]	nom. press. [bar]	speed MIN. [min ⁻¹]	speed MAX. [min ⁻¹]	dimension								
							A [mm]	B [mm]	C [mm]	D [mm]	E [mm]	F [mm]	G [mm]	H [mm]	L [mm]
QHD2-150R-S06D14-		R	150	170	250	2000	78,0	130,5	288,0						
QHD2-150L-S06D14-		L													
QHD2-125R-S06D14-		R	125	190	250	2400	67,5	120,0	277,5						
QHD2-125L-S06D14-		L													
QHD2-110R-S06D14-		R	110	210	350	2600	61,0	113,5	271,0						
QHD2-110L-S06D14-		L													
QHD2-100R-S06D14-SE07E06N		R	100	230	350	2700	56,5	109,0	266,5	64	G1½"	26	58	G1¼"	24
QHD2-100L-S06D14-SE07E06N		L													
QHD2-90R-S06D14-		R	90	240	400	2800	52,5	105,0	262,5						
QHD2-90L-S06D14-		L													
QHD2-82R-S06D14-		R	82	260	400	3000	50,8	101,5	259,0						
QHD2-82L-S06D14-		L													
QHD2-71R-S06D14-		R	71	260	400	3200	48,5	97,0	254,5						
QHD2-71L-S06D14-		L													
QHD2-61R-S06D14-		R	61	270	400	3200	46,3	92,5	250,0						
QHD2-61L-S06D14-		L													
QHD2-56R-S06D14-		R	56	280	400	3200	40,5	90,5	248,0						
QHD2-56L-S06D14-		L													
QHD2-51R-S06D14-		R	51	280	400	3200	36,0	88,5	246,0						
QHD2-51L-S06D14-		L													
QHD2-43R-S06D14-		R	43	280	400	3200	32,5	85,0	242,5						
QHD2-43L-S06D14-		L													

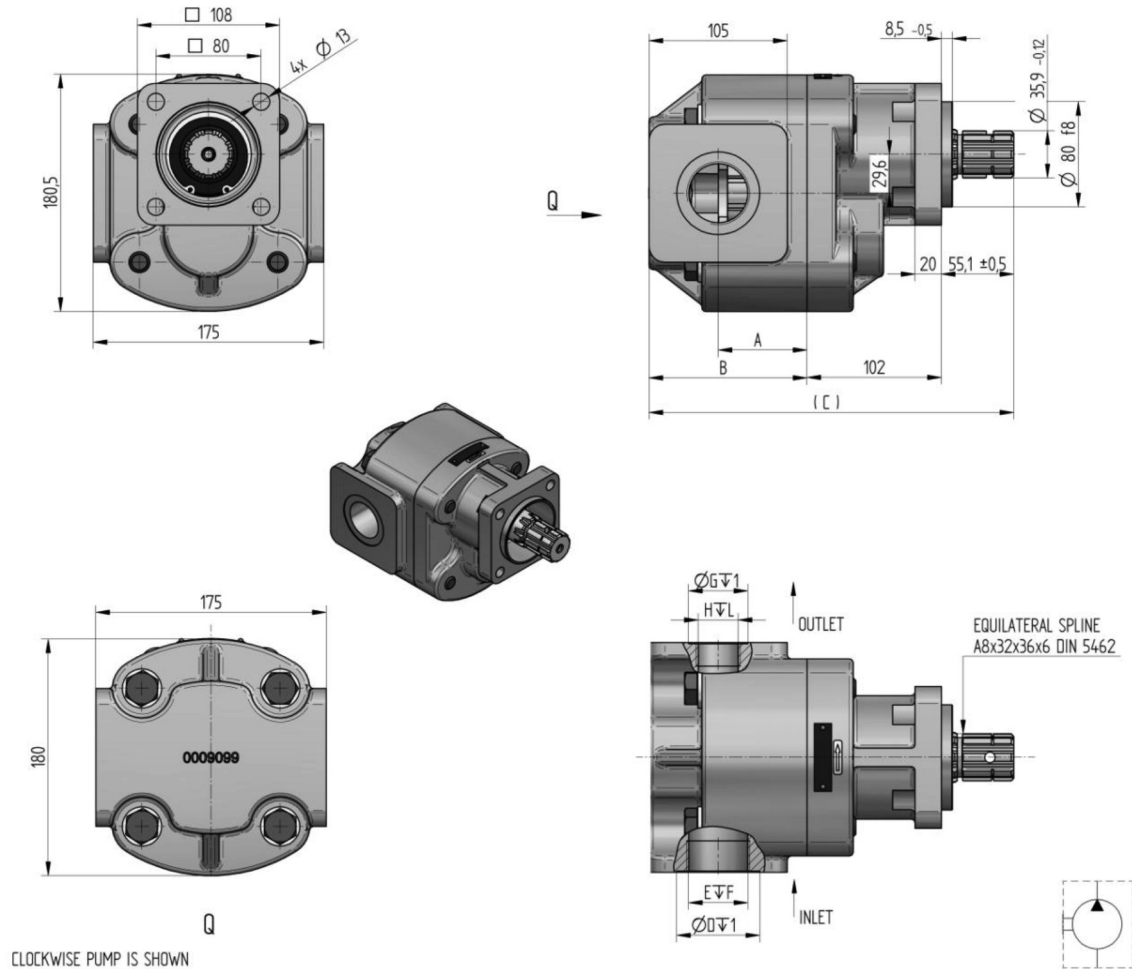

CLOCKWISE PUMP IS SHOWN

Order key	purch. code	direct. of rot.	displacement [cm ³ /1]	nom. press. [bar]	speed MIN. [min ⁻¹]	speed MAX. [min ⁻¹]	dimension								
							A [mm]	B [mm]	C [mm]	D [mm]	E [mm]	F [mm]	G [mm]	H [mm]	L [mm]
QHD2-150R-I02D18-		R	150	170	250	2000	78,0	130,5	287,6						
QHD2-150L-I02D18-		L													
QHD2-125R-I02D18-SG07G05N		R	125	190	250	2400	67,5	120,0	277,1	64	G1½"	26	45	G1"	18
QHD2-125L-I02D18-SG07G05N		L													
QHD2-110R-I02D18-		R	110	210	350	2600	61,0	113,5	270,6						
QHD2-110L-I02D18-		L													
QHD2-100R-I02D18-		R	100	230	350	2700	56,5	109,0	266,1						
QHD2-100L-I02D18-		L													
QHD2-90R-I02D18-		R	90	240	400	2800	52,5	105,0	262,1						
QHD2-90L-I02D18-		L													
QHD2-82R-I02D18-		R	82	260	400	3000	50,8	101,5	258,6						
QHD2-82L-I02D18-		L													
QHD2-71R-I02D18-		R	71	260	400	3200	48,5	97,0	254,1						
QHD2-71L-I02D18-		L													
QHD2-61R-I02D18-		R	61	270	400	3200	46,3	92,5	249,6						
QHD2-61L-I02D18-		L													
QHD2-56R-I02D18-		R	56	280	400	3200	40,5	90,5	247,6						
QHD2-56L-I02D18-		L													
QHD2-51R-I02D18-		R	51	280	400	3200	36,0	88,5	254,6						
QHD2-51L-I02D18-		L													
QHD2-43R-I02D18-		R	43	280	400	3200	32,5	85,0	242,1						
QHD2-43L-I02D18-		L													

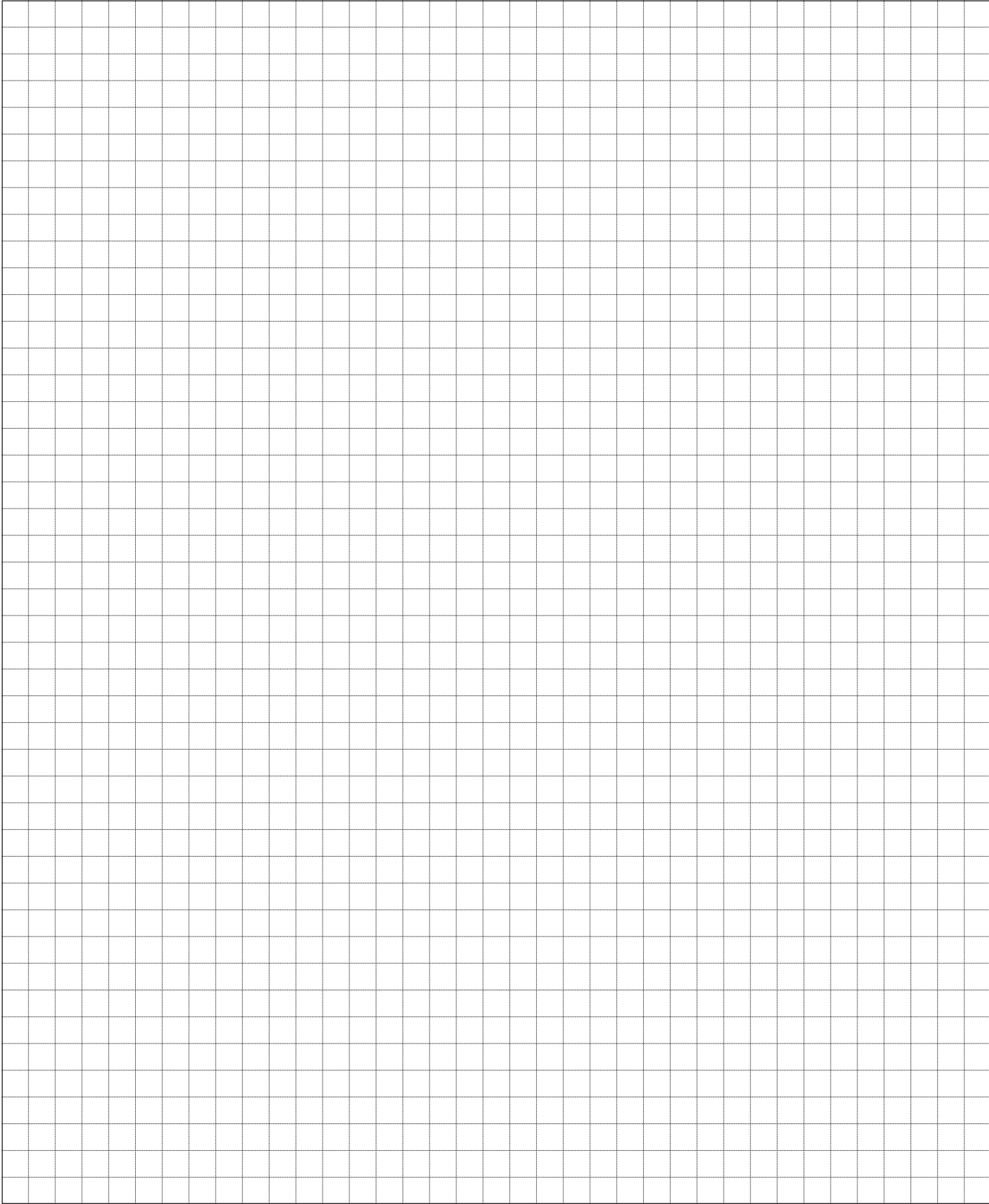

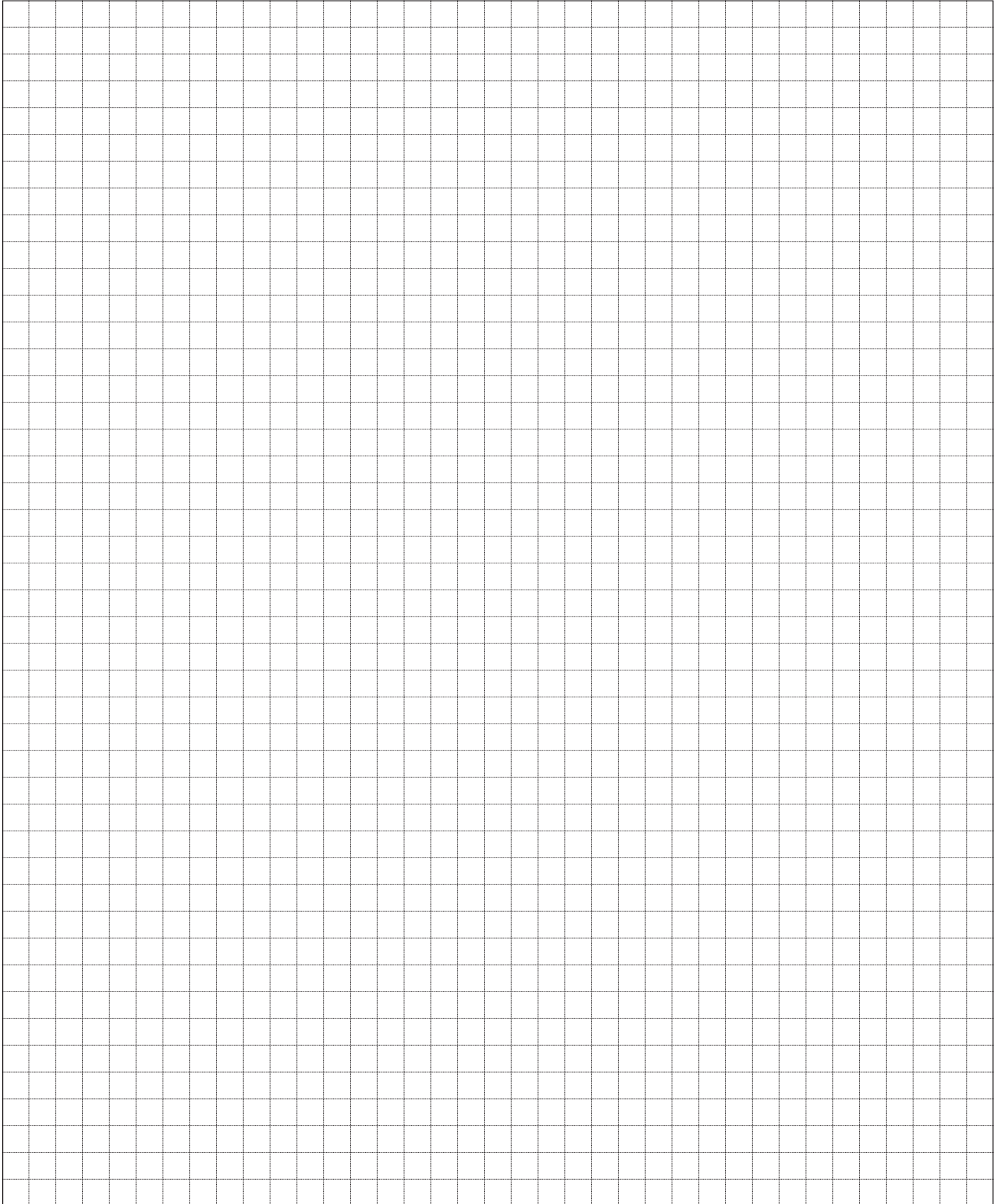



jihostroj
AERO TECHNOLOGY & HYDRAULICS

JIHOSTROJ a.s.
Budějovická 148
CZ 382 32 Velešín
Czech Republic
tel.: +420 380 340 511
fax: +420 380 340 612
e-mail: mailbox@jihostroj.cz
http: //www.jihostroj.com

GPS 48°49'51.748" N 14°27'40.770" E

