

**Displacement** from 2 to 18 ccm  
**Pressure** up to 280 bar  
**Speed** from 500 to 4000 RPM

## GEAR PUMPS



## TABLE OF CONTENTS

BASIC DESCRIPTION .....	2
BASIC PARTS OF PUMP .....	2
PARAMETER TABLE .....	3
FORMULAS USED FOR CALCULATION .....	4
PUMP EFFICIENCIES .....	4
WORKING LIQUID .....	5
PRESSURE LOAD .....	5
DIRECTION OF ROTATION .....	6
REVERSIBLE DESIGN .....	6
FLOW RATE AND POWER CURVES .....	7
ORDER KEY - SINGLE VERSION .....	10
ORDER KEY - MULTIPLE VERSION .....	11
COMBINATIONS OF FLANGES AND SHAFTS .....	12
FLANGES DESIGN .....	13
DRIVE SHAFTS .....	14
LIQUID INLET AND OUTLET CONNECTION .....	16
CATALOGUE SHETS OF J SERIES BASIC DESIGNS .....	17
NOTES .....	23

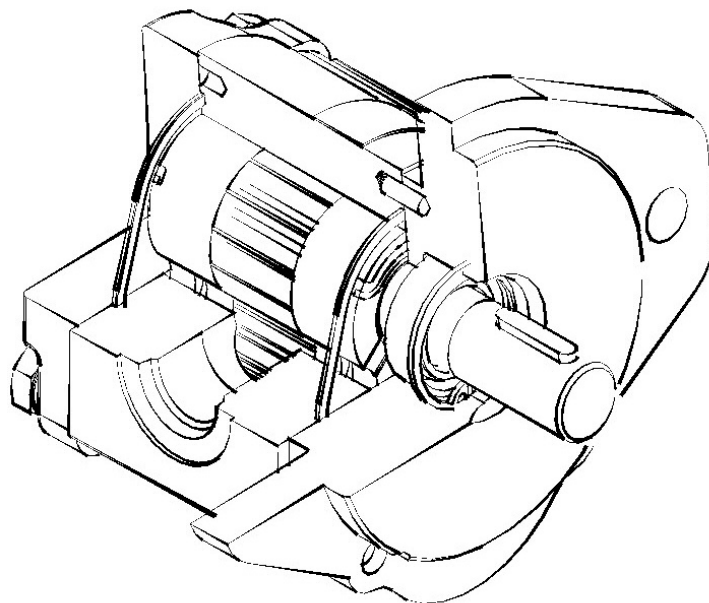

## DESCRIPTION

- J line pumps with external gearing can be used in advance hydraulic systems of measuring capacity (approx. up to 12 kW), with high serviceability and long service life. A wide range of types with various driving units, joint flanges, liquid inlets and outlets enable their application in varied hydraulic circuits of both stationary and mobile equipment and machinery. They are available in single-direction or reverse design with internal or external drainage. Furthermore, they are available in multiple versions (up to 5 sections) with separate inlets working liquid in individual sections or with one common inlet. On request, individual sections can be removed.
- The basic version consists of several parts. The pump body is made of a heavy duty aluminium alloy. The cover and the flange are made of grey cast iron or aluminium alloy. The flange types used as well as the form inlets and outlets working liquid (located laterally – in the body or axially – in the cover) meet all worldwide standards. The gear wheels are optimized for low-noise applications. They show a high quality surface, are supported in aluminium bearing liners and continuously lubricated and cooled by working liquid.

## BASIC PARTS OF PUMP

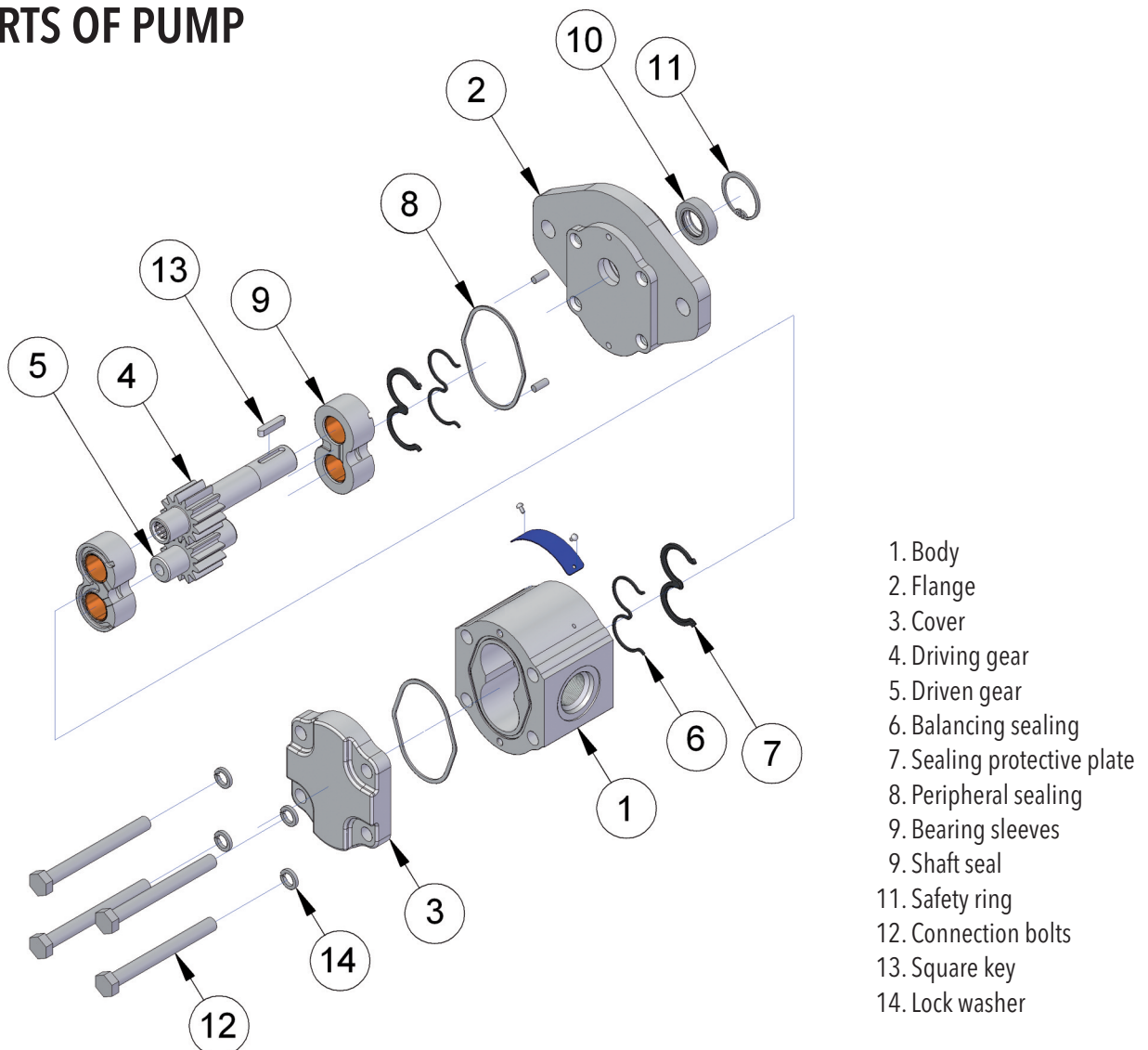

1. Body
2. Flange
3. Cover
4. Driving gear
5. Driven gear
6. Balancing sealing
7. Sealing protective plate
8. Peripheral sealing
9. Bearing sleeves
9. Shaft seal
11. Safety ring
12. Connection bolts
13. Square key
14. Lock washer

## PARAMETER TABLE

Nominal Size Parameters		Sym.	Unit	J 2	J 3	J 4	J 5	J 6	J 7
Actual displacement		$V_g$	[cm <sup>3</sup> ]	2.00	3.01	4.01	5.01	6.02	7.02
Rotation speed	nominal	$n_n$	[min <sup>-1</sup> ]	1500	1500	1500	1500	1500	1500
	minimum	$n_{min}$	[min <sup>-1</sup> ]	500	500	500	500	500	500
	maximum	$n_{max}$	[min <sup>-1</sup> ]	4000	4000	4000	4000	3600	3500
Pressure at inlet*	minimum	$p_{1min}$	[bar]	-0.3	-0.3	-0.3	-0.3	-0.3	-0.3
	maximum	$p_{1max}$	[bar]	0.5	0.5	0.5	0.5	0.5	0.5
Pressure at outlet**	max. continuous	$p_{2n}$	[bar]	280	280	280	280	280	280
	maximum	$p_{2max}$	[bar]	300	300	300	300	300	300
	peak	$p_3$	[bar]	310	310	310	310	310	310
Nominal flow rate (min.) at $n_n$ and $p_{2n}$		$Q_n$	[dm <sup>3</sup> .min <sup>-1</sup> ]	2.68	4.07	5.43	7.01	8.37	9.73
Maximum flow rate at $n_{max}$ a $p_{2max}$		$Q_{max}$	[dm <sup>3</sup> .min <sup>-1</sup> ]	7.95	10.85	14.48	18.69	20.09	24.25
Nominal input power (max.) at $n_n$ and $p_{2n}$		$P_n$	[kW]	1.2	1.8	2.4	3.0	3.6	4.2
Maximum input power at $n_{max}$ a $p_{2max}$		$P_{max}$	[kW]	3.3	4.9	6.6	8.2	8.9	9.5
Weight		$m$	[kg]	1.75	1.80	1.85	1.90	1.95	1.95

Nominal Size Parameters		Sym.	Unit	J 8	J 10	J 11	J 12	J 15
Actual displacement		$V_g$	[cm <sup>3</sup> ]	8.02	10.03	11.03	12.03	15.01
Rotation speed	nominal	$n_n$	[min <sup>-1</sup> ]	1500	1500	1500	1500	1500
	minimum	$n_{min}$	[min <sup>-1</sup> ]	500	500	500	500	500
	maximum	$n_{max}$	[min <sup>-1</sup> ]	3100	2800	2500	2400	2200
Pressure at inlet*	minimum	$p_{1min}$	[bar]	-0.3	-0.3	-0.3	-0.3	-0.3
	maximum	$p_{1max}$	[bar]	0.5	0.5	0.5	0.5	0.5
Pressure at outlet**	max. continuous	$p_{2n}$	[bar]	280	250	235	220	190
	maximum	$p_{2max}$	[bar]	300	270	255	240	210
	peak	$p_3$	[bar]	310	280	265	250	220
Nominal flow rate (min.) at $n_n$ and $p_{2n}$		$Q_n$	[dm <sup>3</sup> .min <sup>-1</sup> ]	11.08	13.80	15.18	16.49	20.60
Maximum flow rate at $n_{max}$ a $p_{2max}$		$Q_{max}$	[dm <sup>3</sup> .min <sup>-1</sup> ]	24.50	25.76	26.80	26.38	32.80
Nominal input power (max.) at $n_n$ and $p_{2n}$		$P_n$	[kW]	4.8	5.3	5.5	5.6	6.0
Maximum input power at $n_{max}$ a $p_{2max}$		$P_{max}$	[kW]	9.9	10.7	9.6	9.9	9.6
Weight		$m$	[kg]	2.00	2.10	2.10	2.20	2.45

\* Inlet pressure in the reversible design can be up to  $p_1 = p_{2n} - 70$  bar max. External drainage must be used in case of the reversible design.

\*\* Outlet pressure in the reversible design is **10% lower** than shown in the table (depending on operating conditions - it is necessary to consult with the manufacturer).

## FORMULAS USED FOR CALCULATION

Flow rate  
 $Q$

$$Q = \frac{V_g \cdot n}{1000} \cdot \eta_v \quad [\text{dm}^3 \cdot \text{min}^{-1}]$$

$V_g$  [cm<sup>3</sup>] pump displacement  
 $n$  [min<sup>-1</sup>] rotation speed  
 $\eta_v$  [-] volumetric efficiency

Displacement  
 $V_g$

$$V_g = \frac{Q \cdot 1000}{n \cdot \eta_v} \quad [\text{cm}^3]$$

Torque  
 $M_k$

$$M_k = \frac{V_g \cdot p}{20 \cdot \pi \cdot \eta_m} \quad [\text{Nm}]$$

$p$  [bar] required pressure at outlet  
 $\eta_m$  [-] mechanical efficiency

Input power  
 $P$

$$P = \frac{V_g \cdot n \cdot p}{600 \cdot 1000 \cdot \eta_t} \quad [\text{kW}]$$

$\eta_t$  [-] total efficiency

## PUMP EFFICIENCIES

Volumetric efficiency

$\eta_v$

It determines the amount of flow losses. Its value is  $\eta_v = 0,92 \div 0,98$  (depending on rotation speed, viscosity of working liquid and outlet pressure). It can be expressed as follows:

$$\eta_v = \frac{Q_{act.}}{Q_{theor}} \quad [-]$$

$Q_{act.}$  [dm<sup>3</sup> · min<sup>-1</sup>] actual flow rate  
 $Q_{theor}$  [dm<sup>3</sup> · min<sup>-1</sup>] theoretical flow rate

Mechanical efficiency

$\eta_m$

It determines mechanical losses. Its value is about  $\eta_m = 0,85$ . It can be expressed as follows:

$$\eta_m = \frac{M_{theor}}{M_{act.}} \quad [-]$$

$M_{act.}$  [Nm] actual torque  
 $M_{theor}$  [Nm] theoretical torque

Total efficiency

$\eta_t$

t is defined as product of  $\eta_n$  and  $\eta_m$  and determines difference between theoretical and actual required input power:

$$\eta_t = \eta_v \cdot \eta_m = \frac{P_{theor}}{P_{act.}} \quad [-]$$

$P_{act.}$  [kW] actual input power  
 $P_{theor}$  [kW] theoretical input power

## WORKING LIQUID

- Mineral oils for hydraulic drives
- Hydraulic liquids based on plant oils suitable for hydraulic drives

### Liquid temperature

- $t = -20 \div +80$  [°C]  
when used with FKM (Viton) seal up to 120 [°C]

### Cinematic viscosity

- Recommended (during continuous operation):  $\nu = 20 \div 80 \cdot 10^{-6} [\text{m}^2 \cdot \text{s}^{-1}]$
- Maximum (cold starting, at viscosity  $>1000$ , operating pressure  $<10$  bar is permissible, speed  $<1500 \cdot \text{min}^{-1}$ ):  $\nu = 1200 \cdot 10^{-6} [\text{m}^2 \cdot \text{s}^{-1}]$
- Minimum (operating mode at  $10 \cdot 10^{-6}$  up  $20 \cdot 10^{-6}$  should be consulted with manufacturer):  $\nu = 10 \cdot 10^{-6} [\text{m}^2 \cdot \text{s}^{-1}]$

### Filtration coefficient $\beta_\alpha$

$\beta_{25\ 75} \geq$  (for pressure  $p_2 < 200$  bar)  
 $\beta_{10\ 75} \geq$  (for pressure  $p_2 > 200$  bar)

### Liquid contamination class according to ISO 4406

21/18/15 (for pressure  $p_2 < 200$  bar)  
20/17/14 (for pressure  $p_2 > 200$  bar)

### Liquid contamination class according to NAS 1638

10 (for pressure  $p_2 < 200$  bar)  
8 (for pressure  $p_2 > 200$  bar)

## PRESSURE LOAD

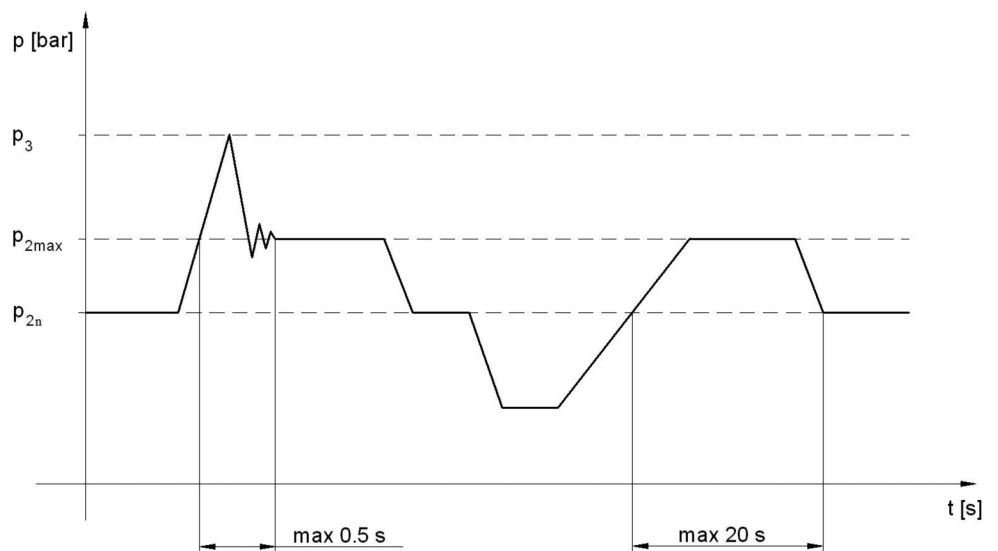

- $p_{2n}$  **max. contin. pressure** Max. working pressure, at which the pump can be operated without time limitation.
- $p_{2max}$  **max. pressure** Maximum pressure permissible for a short time, max. 20s.
- $p_3$  **peak pressure** Short-time pressure (fractions of a second) arising in case of a sudden change of the operating mode; any excess of this pressure during operation is impermissible.

## DIRECTION OF ROTATION

- Determine direction of rotation by looking at the drive shaft. The pump can only be used in the specified direction of rotation.

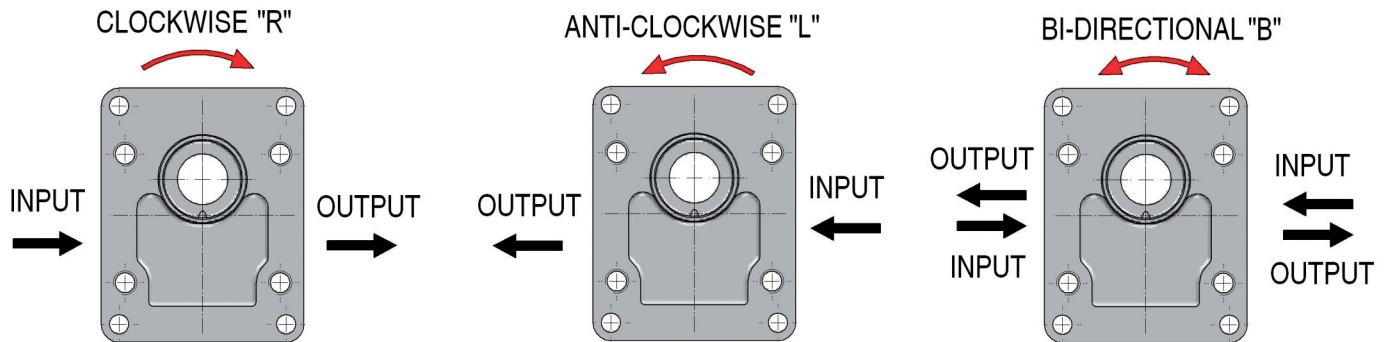

## REVERSIBLE DESIGN

- The pumps with the possibility of bidirectional rotation have a different internal arrangement requiring drainage. Two types of drain are used - internal and external. The internal drainage is always interconnected with the outlet by means of valves. The external drainage is solved by an orifice located in the cover opposite the driven gear.

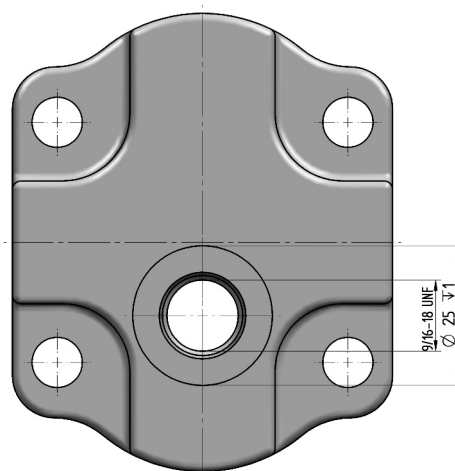

## J FLOW RATE AND POWER CURVES

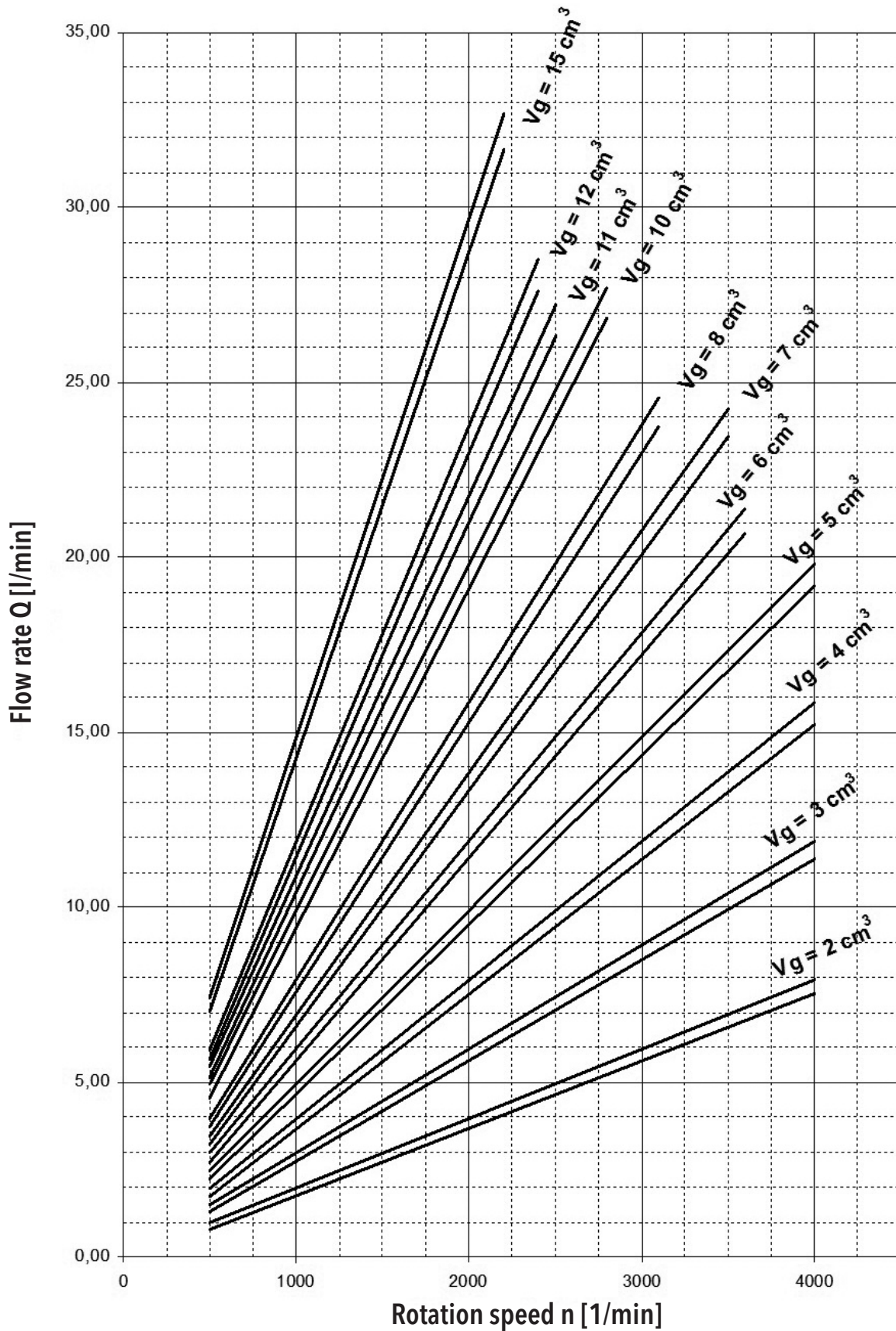

Above curves apply to ISO Vg 46 oil at temperature  $t = 45^{\circ}\text{C}$ .

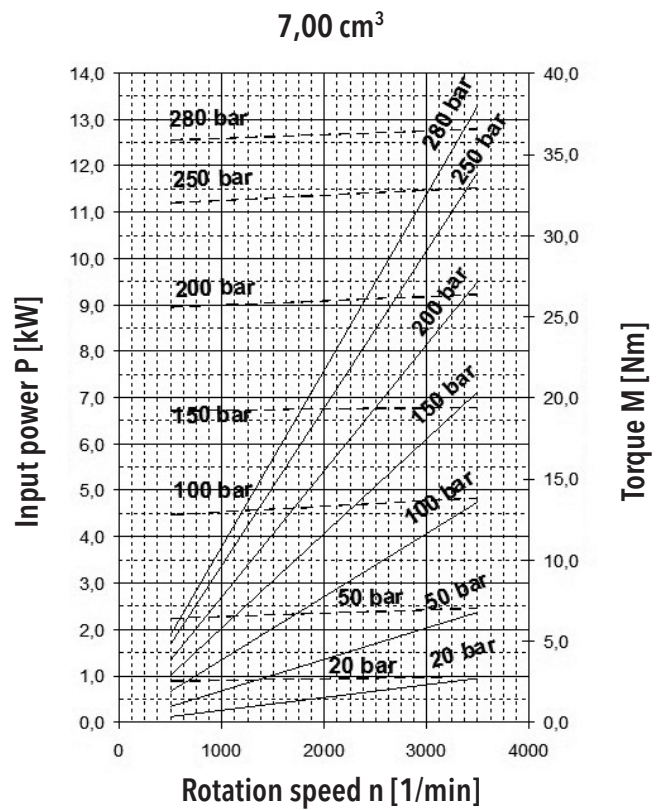
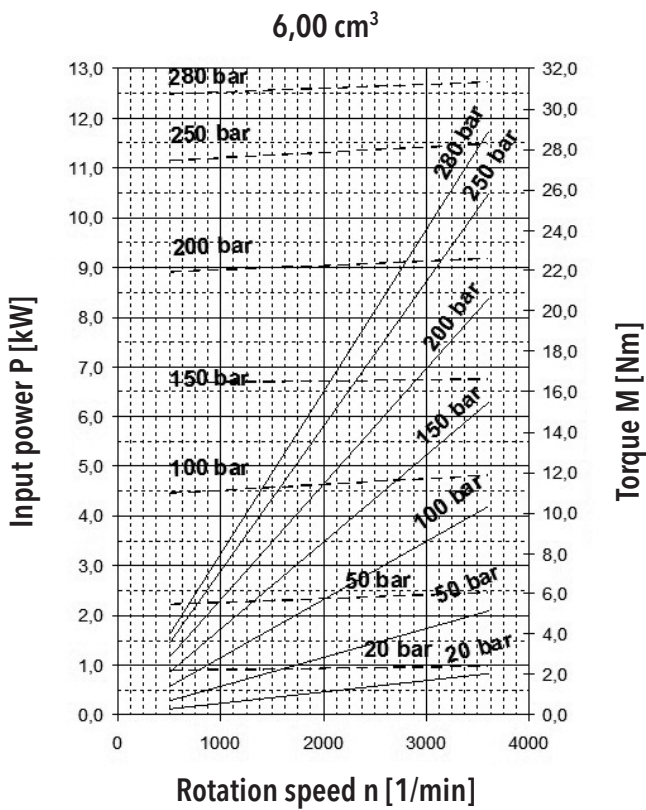
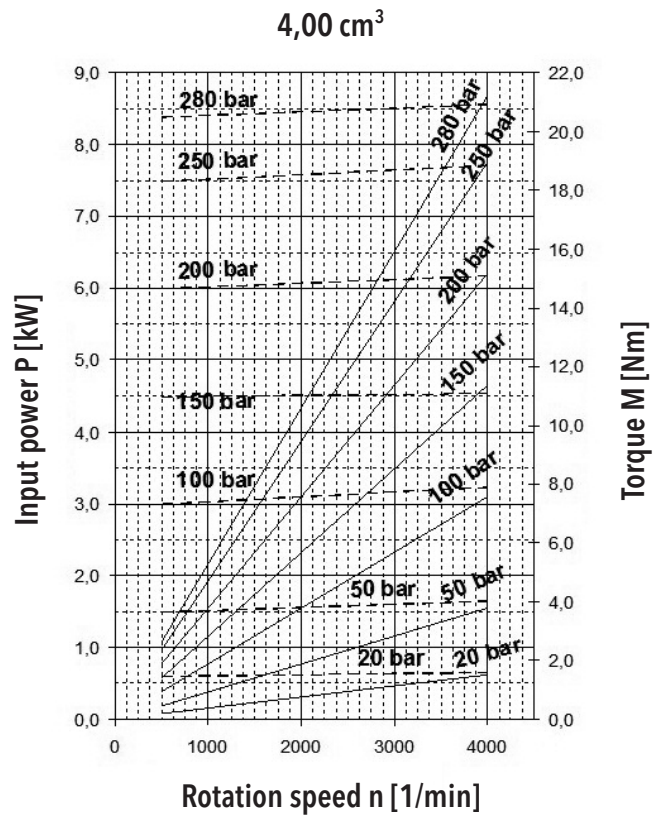
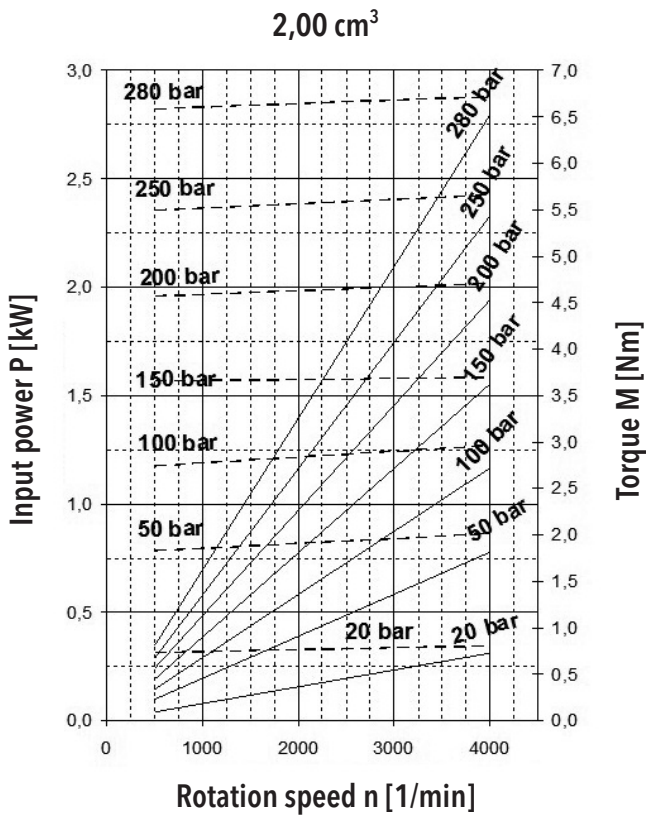

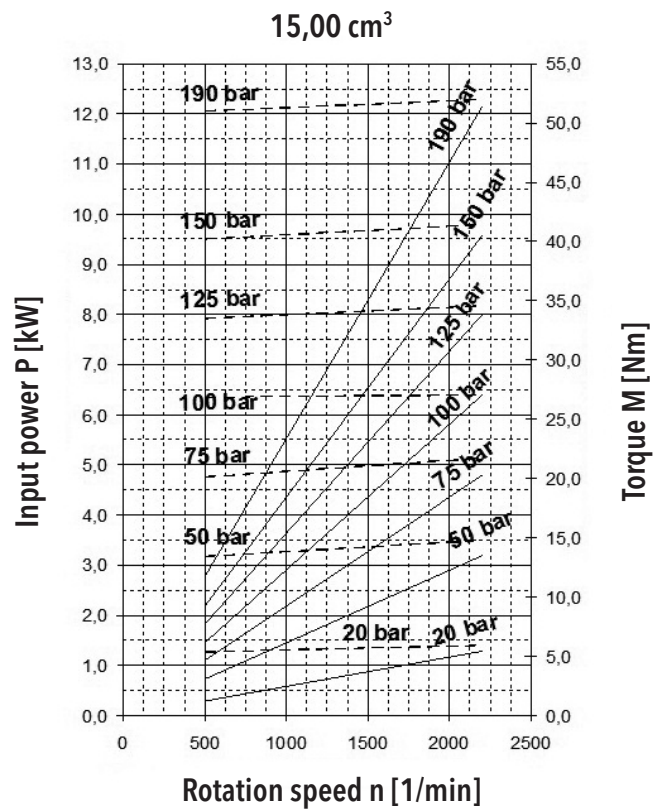
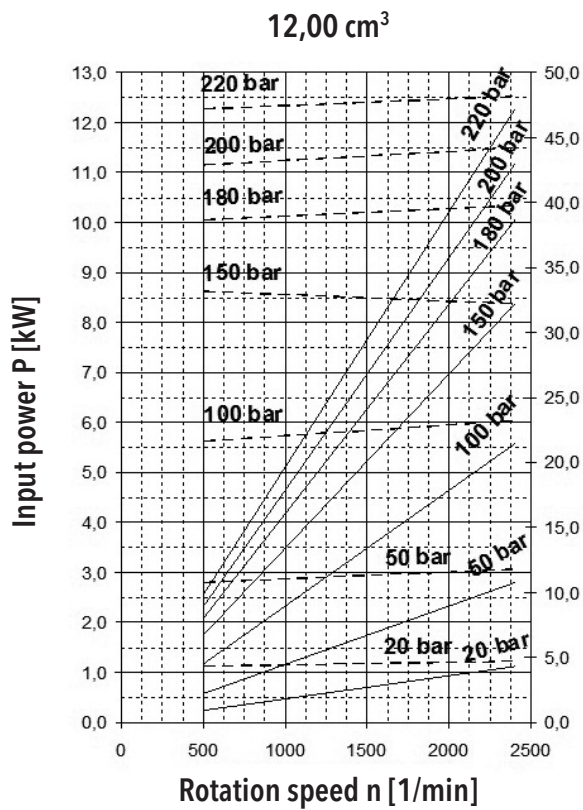
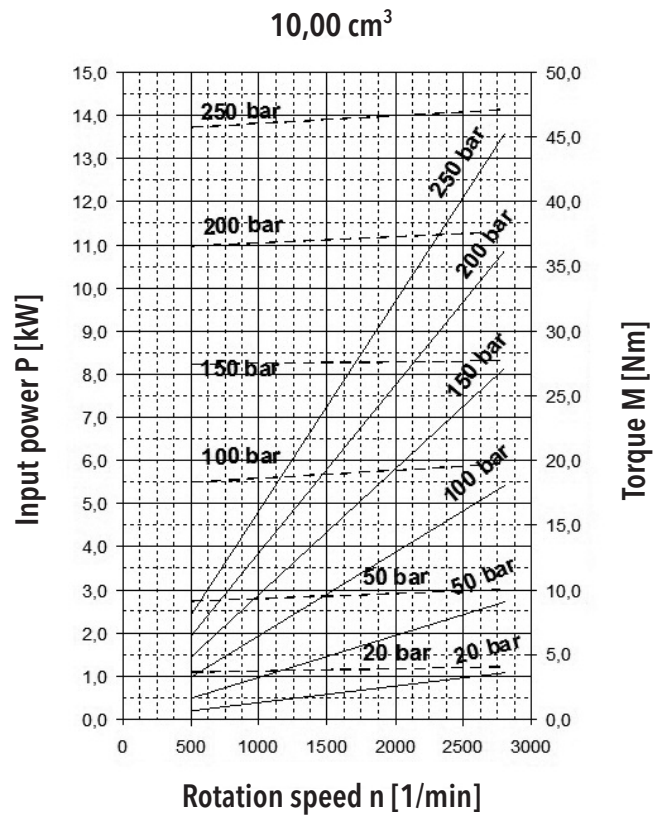
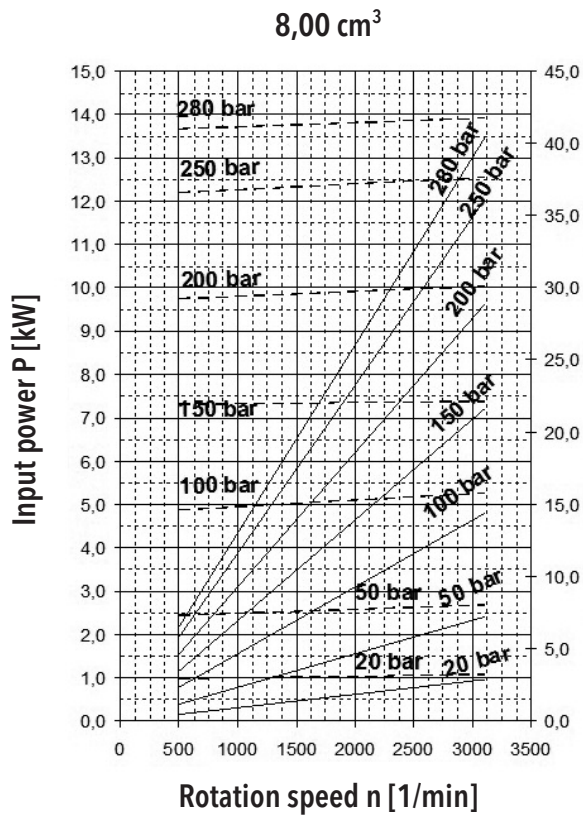

# ORDER KEY - SINGLE VERSION

**J - 12 R - S01 D03 - S G04 G03 - V . 001**

Code	Type
J	J Series Gear Pump
JK	J Series Gear Pump short version

Code	Displacement [cm <sup>3</sup> ]
2	2
3	3
4	4
5	5
6	6
7	7
8	8
9	9
10	10
11	11
12	12
13	13
14	14
15	15
18	18
XX	Other displacements on request

Code	Direction of rotation
R	Clockwise
L	Anti-clockwise
B	Bi-directional

Code	Flange design	
R03		Square flange, centre ring $\varnothing 80$
R05		Rectangular flange, centre ring $\varnothing 36,5$
S01		SAE AA, centre ring $\varnothing 50,8$
S02		SAE A, centre ring $\varnothing 82,5$
F01		ISO, centre ring $\varnothing 45,25$
Z		Special desing

Code	Location of inlets and outlets	
S		Side (in the body)
R		Axial (in the cover)
C		Combination

Code	Special arrangements
-	No special arrangements
001	With front-end bearing
004	Without shaft seal

Code	Seal material
N	NBR
V	FKM (VITON)
H	HNBR

Code	Drive shaft desing	
C05		Cone 1:8 Key width 3
C06		Cone 1:8 Key width 2,4
D02		Spline 20/40 - 30° SAE 9T; l=9
D03		Spline 20/40 - 30° SAE 9T; l=27
D04		Spline 16/32 - 30° SAE 9T; l=32
D05		Spline 16/32 - 30° SAE 8T; l=32
K05		Cross coupling 4,37
K06		Cross coupling 5
V06		Cylindric $\varnothing 12$ Key 3; M10; l=31,5
V07		Cylindric $\varnothing 12,7$ Key 3,18; l=27
V08		Cylindric $\varnothing 12,7$ Key 3,18; l=38,2
V09		Cylindric $\varnothing 15,88$ Key 3,97; l=32
V10		Cylindric $\varnothing 16$ 1/4" - 20UNC THD
Z		Special desing

Code	Liquid inlet and outlet connection shape	
M03		Thread M 14x1,5
M05		Thread M 18x1,5
M07		Thread M 22x1,5
G01		Thread BSP G1/4
G02		Thread BSP G3/8
G03		Thread BSP G1/2
G04		Thread BSP G3/4
U02		Thread 9/16-18 UNF-2B
U03		Thread 3/4-16 UNF-2B
U04		Thread 7/8-14 UNF-2B
R02		Thread 3/8-18NPT
R03		Thread 1/2-14NPT
H03		Fitting $\varnothing 8$ ; Square 4xM6 $\varnothing 30$
H04		Fitting $\varnothing 12$ ; Square 4xM6 $\varnothing 30$
H05		Fitting $\varnothing 15$ ; Square 4xM6 $\varnothing 35$
H06		Fitting $\varnothing 20$ ; Square 4xM6 $\varnothing 40$
S02		Fitting Square 4xM8/25 15x25, 15
Z		Special desing

An example of designation for the J clockwise pump with displacement of 2cm<sup>3</sup>, rectangular flange - centre ring  $\varnothing 30$ , cylindrical shaft  $\varnothing 12$ , BSP inlets sides, FKM seal and with front-end bearing: **J-2R-R03V06-SG04G03-V.001**

## ORDER KEY - MULTIPLE VERSION

**J - 2 / 2 R - R03 V06 - S G04 G03 / G04 G03 - V . 001**

Code	Type
J	J Series Gear Pump
JK	J Series Gear Pump short version





  

Code	Displacement [cm <sup>3</sup> ]
2	2
3	3
4	4
5	5
6	6
7	7
8	8
9	9
10	10
11	11
12	12
13	13
14	14
15	15
18	18
XX	Other displacements on request



  

Code	Direction of rotation
R	Clockwise
L	Anti-clockwise
B	Bi-directional

Code	Flange design
R03	 Square flange, centre ring Ø80
R05	 Rectangular flange, centre ring Ø36,5
S01	 SAE AA, centre ring Ø50,8
S02	 SAE A, centre ring Ø82,5
F01	 ISO, centre ring Ø45,25
Z	Special desing

Code	Location of inlets and outlets
S	 Side (in the body)
C	 Combination

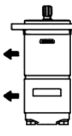











  

Code	Special arrangements
-	No special arrangements
001	With front-end bearing
004	Without shaft seal















  

Code	Seal material
N	NBR
V	FKM (VITON)
H	HNBR

Code	Drive shaft desing
C05	 Cone 1:8 Key width 3
C06	 Cone 1:8 Key width 2,4
D02	 Spline 20/40 - 30° SAE 9T; l=9
D03	 Spline 20/40 - 30° SAE 9T; l=27
D04	 Spline 16/32 - 30° SAE 9T; l=32
D05	 Spline 16/32 - 30° SAE 8T; l=32
K05	 Cross coupling 4,37
K06	 Cross coupling 5
V06	 Cylindric Ø 12 Key 3; M10; l=31,5
V07	 Cylindric Ø 12,7 Key 3,18; l=27
V08	 Cylindric Ø 12,7 Key 3,18; l=38,2
V09	 Cylindric Ø 15,88 Key 3,97; l=32
V10	 Cylindric Ø 16 1/4" - 20UNC THD
Z	Special desing

Code	Liquid inlet and outlet connection shape
M03	 Thread M 14x1,5
M05	 Thread M 18x1,5
M07	 Thread M 22x1,5
G01	 Thread BSP G1/4
G02	 Thread BSP G3/8
G03	 Thread BSP G1/2
G04	 Thread BSP G3/4
U02	 Thread 9/16-18 UNF-2B
U03	 Thread 3/4-16 UNF-2B
U04	 Thread 7/8-14 UNF-2B
R02	 Thread 3/8-18NPT
R03	 Thread 1/2-14NPT
H03	 Fitting Ø8; Square 4xM6 Ø30
H04	 Fitting Ø12; Square 4xM6 Ø30
H05	 Fitting Ø15; Square 4xM6 Ø35
H06	Fitting Ø20; Square 4xM6 Ø40
S02	Fitting Square 4xM8/25 15x25, 15
Z	Special desing

An example of designation for the J two-section clockwise pump with displacements of 2 and 2 cm<sup>3</sup>, rectangular flange centre ring Ø30, cylindrical shaft Ø12, BSP inlets sides, FKM seal and with front-end bearing: **J-2/2R-R03V06-SG04G03/G04G03-V.001**

Note: In case of combination inlets, with the code „C” is respected following sequence of inlets and outlets:

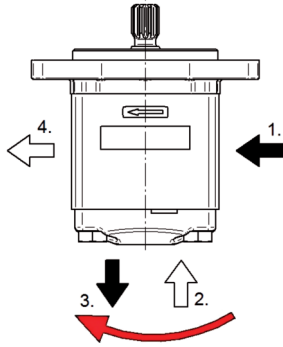

For clockwise and reverse gear pump,  
in direction clockwise

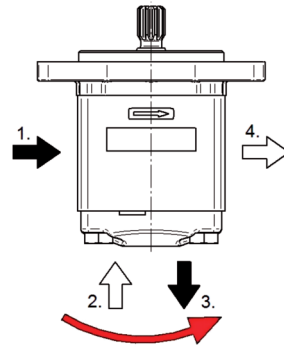

For anti-clockwise gear pump,  
in direction anti-clockwise

For. ex....: J-12R-S01D03-CG04 G04 G03 G03 -N  
1. 2. 3. 4.

## COMBINATIONS OF FLANGES AND SHAFTS

		FLANGE DESIGN				
		R03	R05	S01	S02	F01
DRIVE SHAFT	C05	●	●	●		
	C06	●	●		●	
	D02			●		●
	D03			●	●	●
	D04			●	●	
	D05			●	●	
	K05					●
	K06			●		
	V06	●				
	V07			●		
	V08	●		●	●	●
	V09		●		●	●
V10					●	

## FLANGES DESIGN

**R03:**

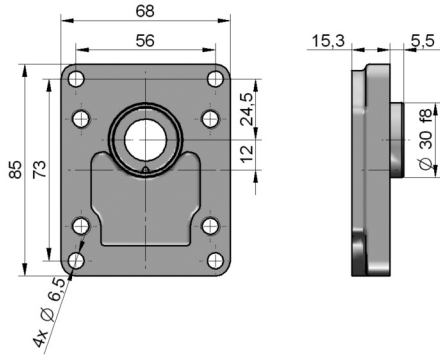

**R05:**

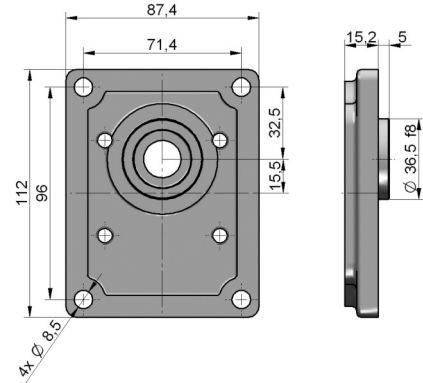

**S01:**

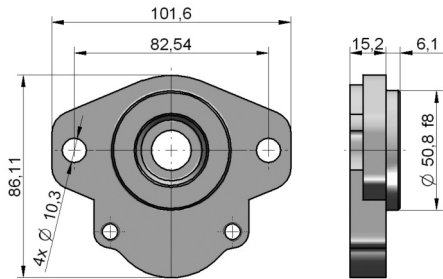

**S02:**

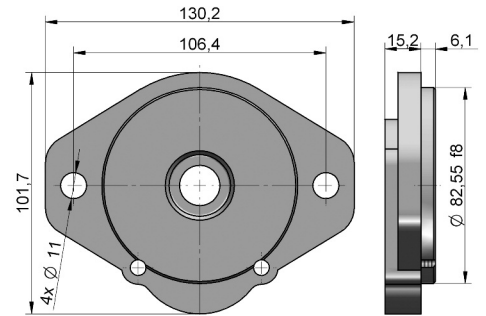

**F01:**

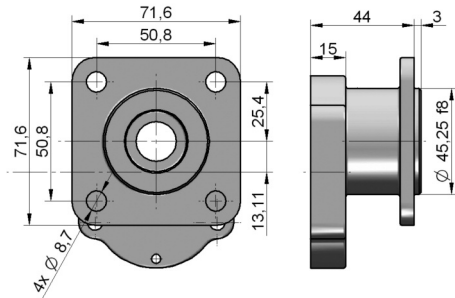

## DRIVE SHAFTS

C05:

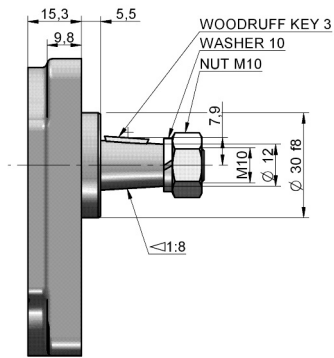

C06:

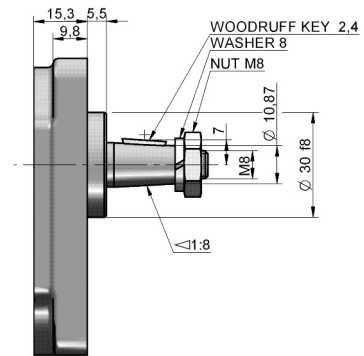

D02:

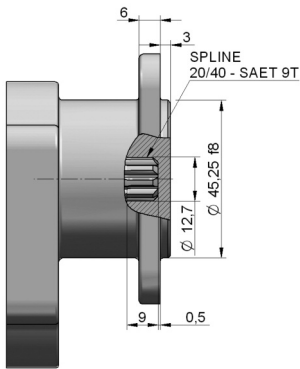

D03:

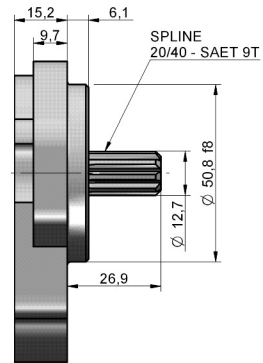

D04:

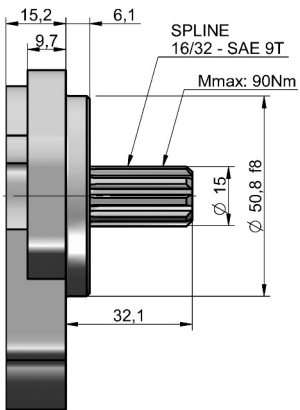

D05:

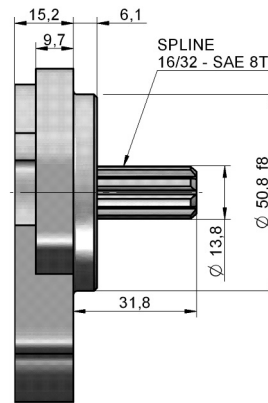

K05:

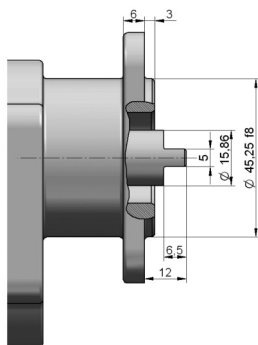

K06:

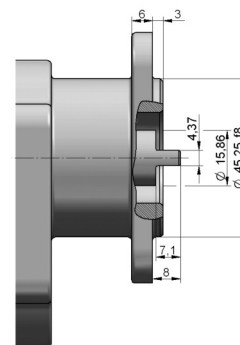

**V06:**

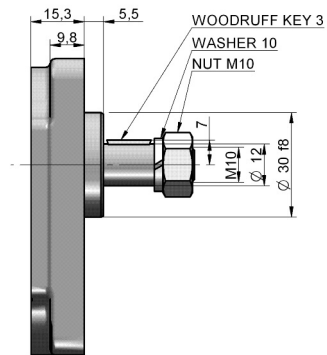

**V07:**

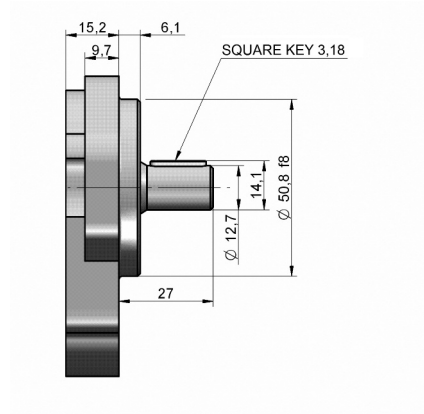

**V08:**

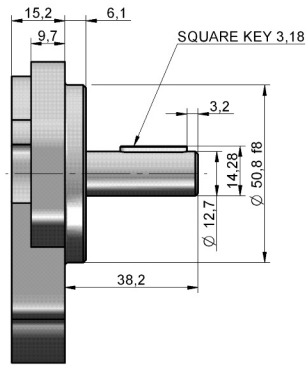

**V09:**

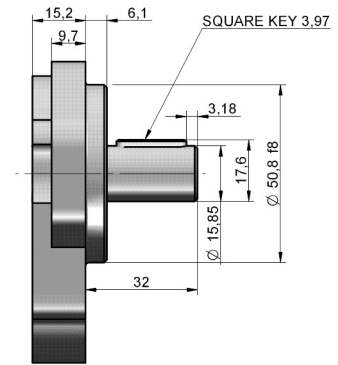

**V10:**

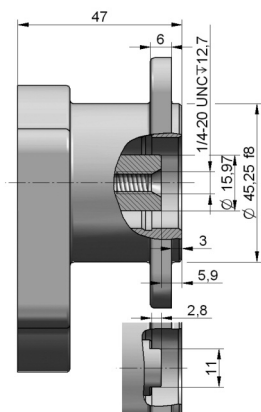

## LIQUID INLET AND OUTLET CONNECTION

### Metric thread according to ISO 6149

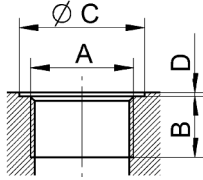

Code	A	B	C	D
M03	M 14 x 1.5	13	22	1
M05	M 18 x 1.5	13	24	1
M07	M 22 x 1.5	14	28	1

### BSPP pipe thread according to ISO 228-1

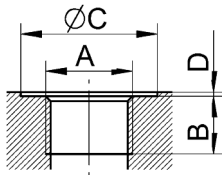

Code	A	B	C	D
G01	G 1/4	12	18	1
G02	G 3/8	13	24	1
G03	G 1/2	14	33	1
G04	G 3/4	16	39	1

### UNF thread according to SAE

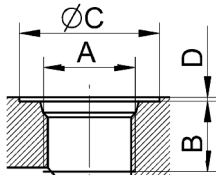

Code	A	B	C	D
U02	9/16 - 18 UNF	13	25	1
U03	3/4 - 16 UNF	15	30	1
U04	7/8 - 14 UNF	17	34	1

### Tapered thread NPT

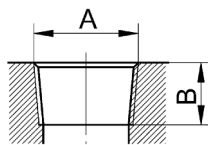

Code	A	B
R02	3/8 - 18 NPT	16.0
R03	1/2 - 14 NPT	20.8

### Flanged fittings according to DIN 8901/8902

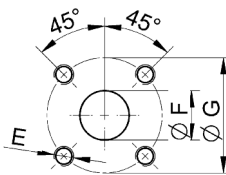

Code	A	B	C
H03	M6	8	30
H04	M6	12	30
H05	M6	15	35
H06	M6	20	40

### Flanged fittings ISO

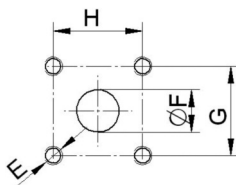

Code	E	F	G	H
S02	1/4 UNC	14.2	25.15	25.15
S03	M8	14.2	25.15	25.15

### Drains

Code	A	B	C	D
U01	7/16-20 UNF 2B	13	21	1
G01	G 1/4	12	18	1

## CATALOGUE SHETS OF J SERIES BASIC DESIGNS

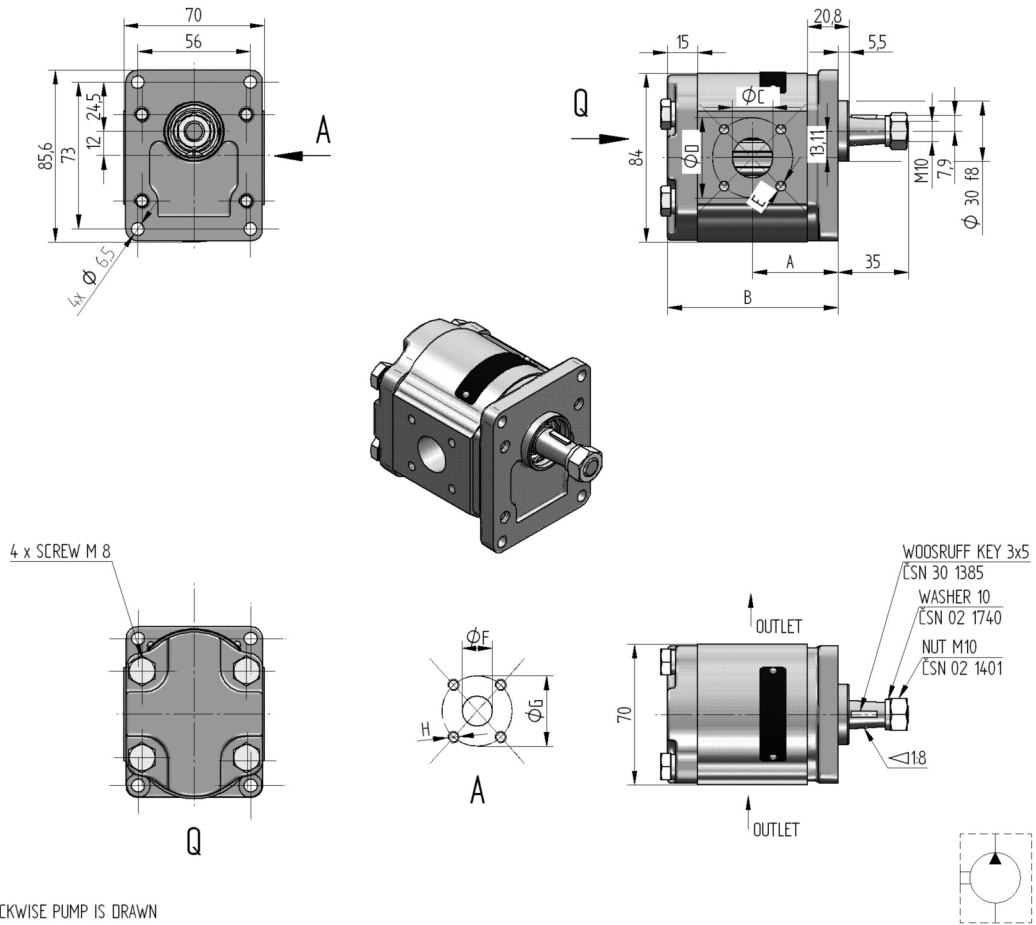

THE CLOCKWISE PUMP IS DRAWN

Order key	purch. code	direct. of rot.	displacement [cm <sup>3</sup> /1]	nom. press. [bar]	speed MIN. [min <sup>-1</sup> ]	speed MAX. [min <sup>-1</sup> ]	dimension							
							A [mm]	B [mm]	C [mm]	D [mm]	E [mm]	F [mm]	G [mm]	H [mm]
J-15R-R03C05-S H06H05-N		R	15	190	500	2200	51.86	103.42	20	40	M6x13	15	35	M6x13
J-15L-R03C05-S H06H05-N		L												
J-12R-R03C05-S H06H05-N		R	12	220	500	2400	47.88	95.46	20	40	M6x13	15	35	M6x13
J-12L-R03C05-S H06H05-N		L												
J-11R-R03C05-S H06H05-N		R	11	235	500	2500	46.55	92.80	20	40	M6x13	15	35	M6x13
J-11L-R03C05-S H06H05-N		L												
J-10R-R03C05-S H06H05-N		R	10	250	500	2800	45.21	90.12	20	40	M6x13	15	35	M6x13
J-10L-R03C05-S H06H05-N		L												
J-8R-R03C05-S H06H05-N		R	8	280	500	3100	42.54	84.79	20	40	M6x13	15	35	M6x13
J-8L-R03C05-S H06H05-N		L												
J-7R-R03C05-S H06H05-N		R	7	280	500	3500	41.21	82.12	20	40	M6x13	15	35	M6x13
J-7L-R03C05-S H06H05-N		L												
J-6R-R03C05-S H06H05-N		R	6	280	500	3600	39.87	79.44	20	40	M6x13	15	35	M6x13
J-6L-R03C05-S H06H05-N		L												
J-5R-R03C05-S H06H05-N		R	5	280	500	4000	38.54	76.78	20	40	M6x13	15	35	M6x13
J-5L-R03C05-S H06H05-N		L												
J-4R-R03C05-S H06H05-N		R	4	280	500	4000	37.20	74.11	20	40	M6x13	15	35	M6x13
J-4L-R03C05-S H06H05-N		L												
J-3R-R03C05-S H06H05-N		R	3	280	500	4000	35.87	71.44	20	40	M6x13	15	35	M6x13
J-3L-R03C05-S H06H05-N		L												
J-2R-R03C05-S H06H05-N		R	2	280	500	4000	34.53	68.76	20	40	M6x13	15	35	M6x13
J-2L-R03C05-S H06H05-N		L												

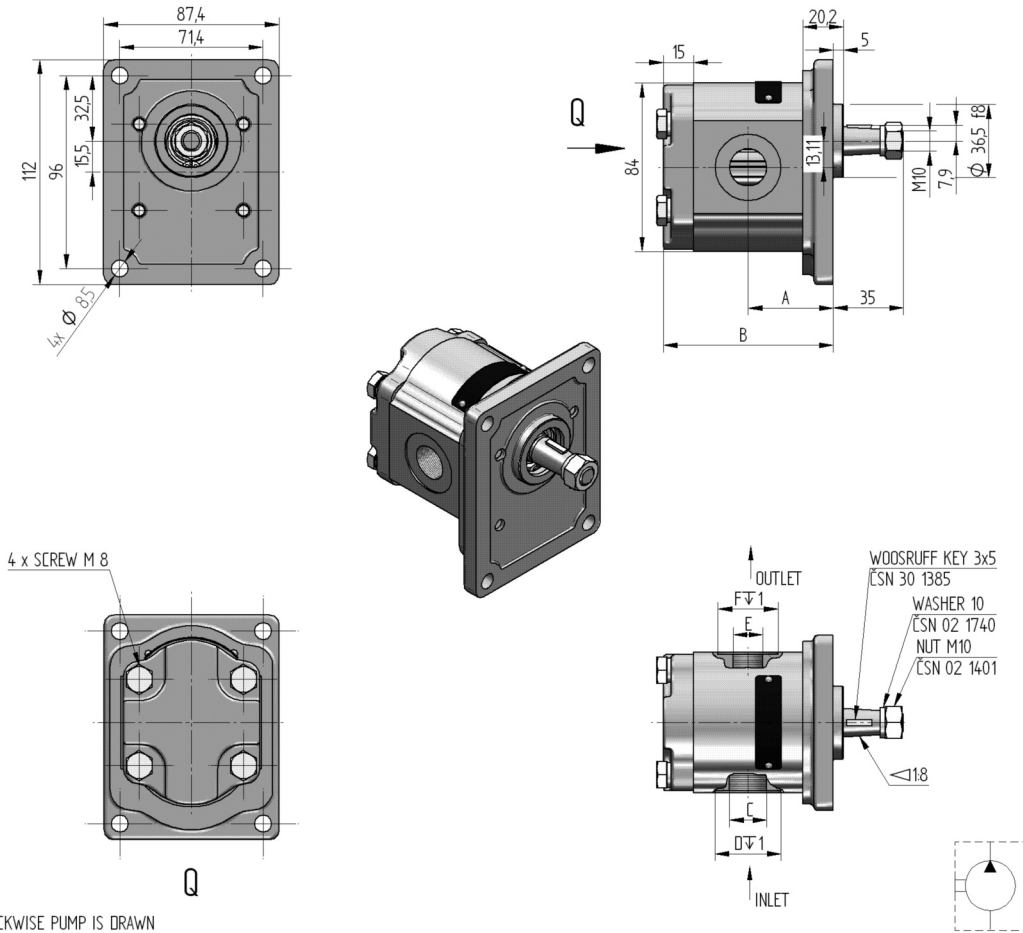

THE CLOCKWISE PUMP IS DRAWN

Order key	purch. code	direct. of rot.	displacement [cm <sup>3</sup> /1]	nom. press. [bar]	speed MIN. [min <sup>-1</sup> ]	speed MAX. [min <sup>-1</sup> ]	dimension					
							A [mm]	B [mm]	C [mm]	D [mm]	E [mm]	F [mm]
J-15R- R05C05-S G03G02-N		R	15	190	500	2200	51.76	103.32	G 1/2x14	Ø 33	G 3/8x13	Ø 24
J-15L- R05C05-S G03G02-N		L										
J-12R- R05C05-S G03G02-N		R	12	220	500	2400	47.78	95.36	G 1/2x14	Ø 33	G 3/8x13	Ø 24
J-12L- R05C05-S G03G02-N		L										
J-11R- R05C05-S G03G02-N		R	11	235	500	2500	46.45	92.70	G 1/2x14	Ø 33	G 3/8x13	Ø 24
J-11L- R05C05-S G03G02-N		L										
J-10R- R05C05-S G03G02-N		R	10	250	500	2800	45.11	90.02	G 1/2x14	Ø 33	G 3/8x13	Ø 24
J-10L- R05C05-S G03G02-N		L										
J-8R- R05C05-S G03G02-N		R	8	280	500	3100	42.45	84.69	G 1/2x14	Ø 33	G 3/8x13	Ø 24
J-8L- R05C05-S G03G02-N		L										
J-7R- R05C05-S G03G02-N		R	7	280	500	3500	41.11	82.02	G 1/2x14	Ø 33	G 3/8x13	Ø 24
J-7L- R05C05-S G03G02-N		L										
J-6R- R05C05-S G03G02-N		R	6	280	500	3600	39.77	79.34	G 1/2x14	Ø 33	G 3/8x13	Ø 24
J-6L- R05C05-S G03G02-N		L										
J-5R- R05C05-S G03G02-N		R	5	280	500	4000	38.44	76.68	G 1/2x14	Ø 33	G 3/8x13	Ø 24
J-5L- R05C05-S G03G02-N		L										
J-4R- R05C05-S G03G02-N		R	4	280	500	4000	37.10	74.01	G 1/2x14	Ø 33	G 3/8x13	Ø 24
J-4L- R05C05-S G03G02-N		L										
J-3R- R05C05-S G03G02-N		R	3	280	500	4000	35.77	71.34	G 1/2x14	Ø 33	G 3/8x13	Ø 24
J-3L- R05C05-S G03G02-N		L										
J-2R- R05C05-S G03G02-N		R	2	280	500	4000	34.43	68.55	G 1/2x14	Ø 33	G 3/8x13	Ø 24
J-2L- R05C05-S G03G02-N		L										

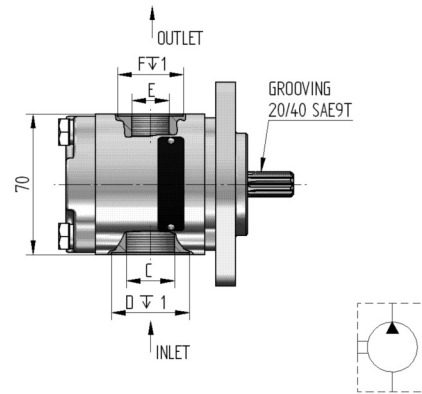
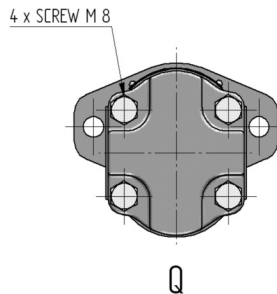
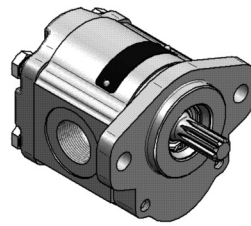
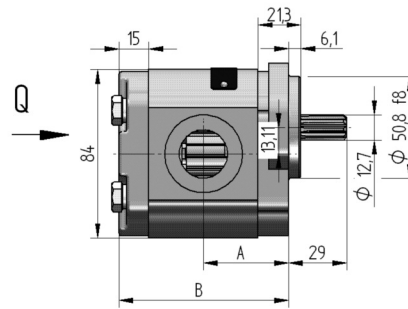
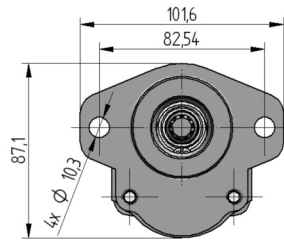

THE CLOCKWISE PUMP IS DRAWN

Order key	purch. code	direct. of rot.	displacement [cm <sup>3</sup> /1]	nom. press. [bar]	speed MIN. [min <sup>-1</sup> ]	speed MAX. [min <sup>-1</sup> ]	dimension					
							A [mm]	B [mm]	C [mm]	D [mm]	E [mm]	F [mm]
J-15R-S01D03-S G04G03-N		R	15	190	500	2200	51.76	103.32	G 3/4x16	Ø 39	G 1/2x14	Ø 33
J-15L-S01D03-S G04G03-N		L										
J-12R-S01D03-S G04G03-N		R	12	220	500	2400	47.78	95.36	G 3/4x16	Ø 39	G 1/2x14	Ø 33
J-12L-S01D03-S G04G03-N		L										
J-11R-S01D03-S G04G03-N		R	11	235	500	2500	46.45	92.70	G 3/4x16	Ø 39	G 1/2x14	Ø 33
J-11L-S01D03-S G04G03-N		L										
J-10R-S01D03-S G04G03-N		R	10	250	500	2800	45.11	90.02	G 3/4x16	Ø 39	G 1/2x14	Ø 33
J-10L-S01D03-S G04G03-N		L										
J-8R-S01D03-S G04G03-N		R	8	280	500	3100	42.44	84.69	G 3/4x16	Ø 39	G 1/2x14	Ø 33
J-8L-S01D03-S G04G03-N		L										
J-7R-S01D03-S G04G03-N		R	7	280	500	3500	41.11	82.02	G 3/4x16	Ø 39	G 1/2x14	Ø 33
J-7L-S01D03-S G04G03-N		L										
J-6R-S01D03-S G04G03-N		R	6	280	500	3600	39.77	79.34	G 3/4x16	Ø 39	G 1/2x14	Ø 33
J-6L-S01D03-S G04G03-N		L										
J-5R-S01D03-S G04G03-N		R	5	280	500	4000	38.44	76.68	G 3/4x16	Ø 39	G 1/2x14	Ø 33
J-5L-S01D03-S G04G03-N		L										
J-4R-S01D03-S G04G03-N		R	4	280	500	4000	37.10	74.01	G 3/4x16	Ø 39	G 1/2x14	Ø 33
J-4L-S01D03-S G04G03-N		L										
J-3R-S01D03-S G04G03-N		R	3	280	500	4000	35.77	71.34	G 3/4x16	Ø 39	G 1/2x14	Ø 33
J-3L-S01D03-S G04G03-N		L										
J-2R-S01D03-S G03G03-N		R	2	280	500	4000	34.43	68.66	G 1/2x14	Ø 33	G 1/2x14	Ø 33
J-2L-S01D03-S G03G03-N		L										

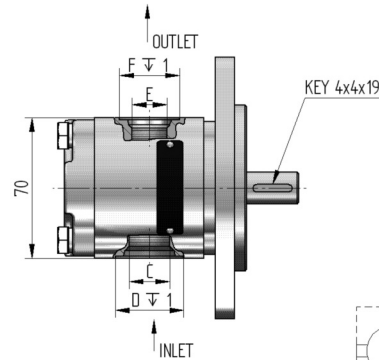
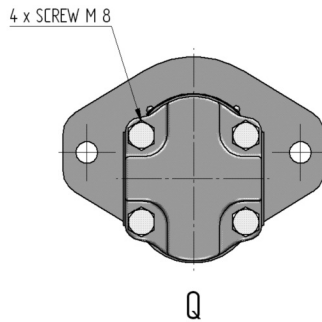
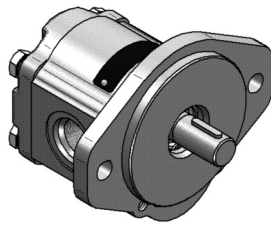
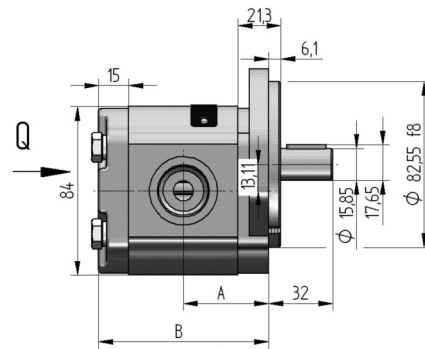
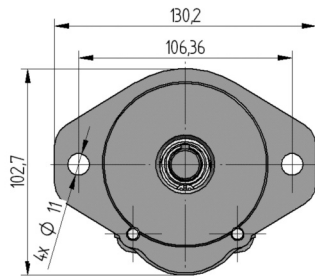

THE CLOCKWISE PUMP IS DRAWN

Order key	purch. code	direct. of rot.	displacement [cm <sup>3</sup> /1]	nom. press. [bar]	speed MIN. [min <sup>-1</sup> ]	speed MAX. [min <sup>-1</sup> ]	dimension					
							A [mm]	B [mm]	C [mm]	D [mm]	E [mm]	F [mm]
J-15R- S02V09-S U04U03-N		R	15	190	500	2200	51.76	103.32	7/8-14UNFx17	Ø 34	3/4-16UNFx15	Ø 30
J-15L- S02V09-S U04U03-N		L										
J-12R- S02V09-S U04U03-N		R	12	220	500	2400	47.78	95.36	7/8-14UNFx17	Ø 34	3/4-16UNFx15	Ø 30
J-12L- S02V09-S U04U03-N		L										
J-11R- S02V09-S U04U03-N		R	11	235	500	2500	46.45	92.70	7/8-14UNFx17	Ø 34	3/4-16UNFx15	Ø 30
J-11L- S02V09-S U04U03-N		L										
J-10R- S02V09-S U04U03-N		R	10	250	500	2800	45.11	90.02	7/8-14UNFx17	Ø 34	3/4-16UNFx15	Ø 30
J-10L- S02V09-S U04U03-N		L										
J-8R- S02V09-S U04U03-N		R	8	280	500	3100	42.44	84.69	7/8-14UNFx17	Ø 34	3/4-16UNFx15	Ø 30
J-8L- S02V09-S U04U03-N		L										
J-7R- S02V09-S U04U03-N		R	7	280	500	3500	41.11	82.02	7/8-14UNFx17	Ø 34	3/4-16UNFx15	Ø 30
J-7L- S02V09-S U04U03-N		L										
J-6R- S02V09-S U04U03-N		R	6	280	500	3600	39.77	79.34	7/8-14UNFx17	Ø 34	3/4-16UNFx15	Ø 30
J-6L- S02V09-S U04U03-N		L										
J-5R- S02V09-S U04U03-N		R	5	280	500	4000	38.44	76.68	7/8-14UNFx17	Ø 34	3/4-16UNFx15	Ø 30
J-5L- S02V09-S U04U03-N		L										
J-4R- S02V09-S U04U03-N		R	4	280	500	4000	37.10	74.01	7/8-14UNFx17	Ø 34	3/4-16UNFx15	Ø 30
J-4L- S02V09-S U04U03-N		L										
J-3R- S02V09-S U04U03-N		R	3	280	500	4000	35.77	71.34	7/8-14UNFx17	Ø 34	3/4-16UNFx15	Ø 30
J-3L- S02V09-S U04U03-N		L										
J-2R- S02V09-S U04U03-N		R	2	280	500	4000	34.43	68.66	7/8-14UNFx17	Ø 34	3/4-16UNFx15	Ø 30
J-2L- S02V09-S U04U03-N		L										

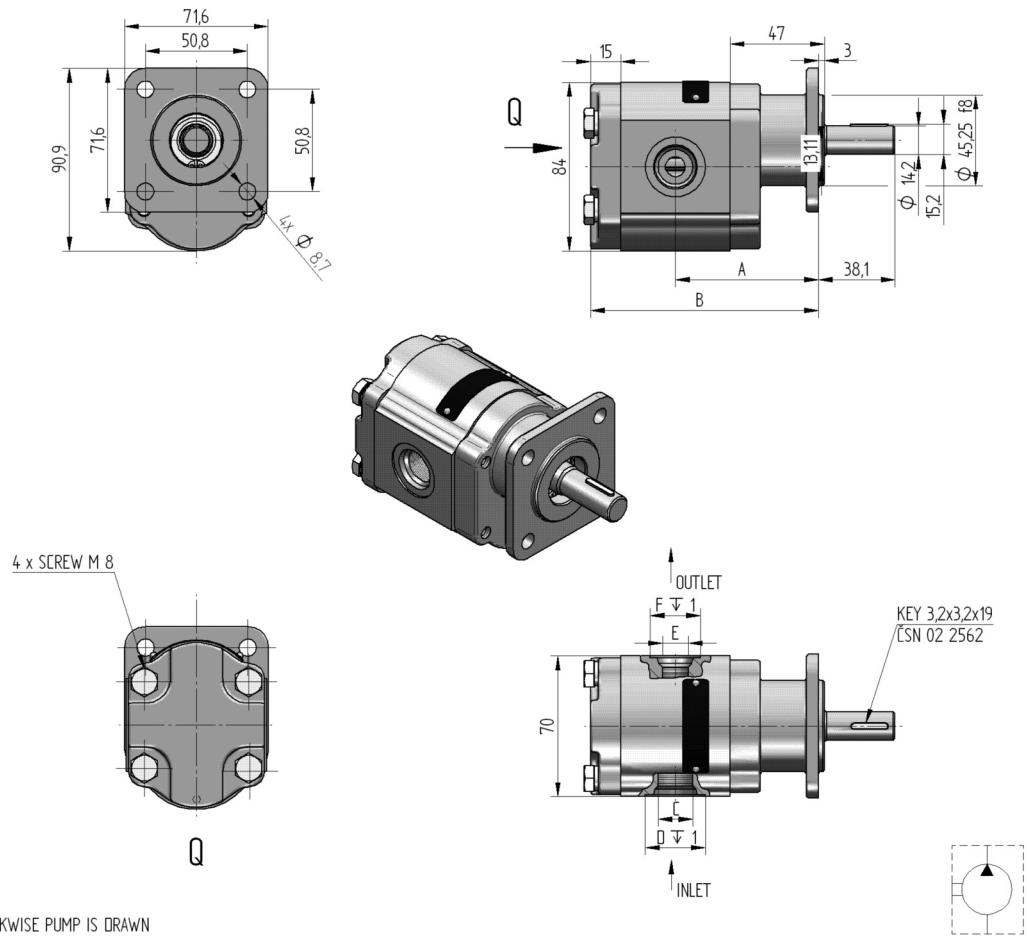

THE CLOCKWISE PUMP IS DRAWN

Order key	purch. code	direct. of rot.	displacement [cm <sup>3</sup> /1]	nom. press. [bar]	speed MIN. [min <sup>-1</sup> ]	speed MAX. [min <sup>-1</sup> ]	dimension					
							A [mm]	B [mm]	C [mm]	D [mm]	E [mm]	F [mm]
J-15R- F01V08-S U03U02-N		R	15	190	500	2200	80.56	132.12	3/4-16UNFx15	Ø 30	9/16-18UNFx13	Ø 25
J-15L- F01V08-S U03U02-N		L										
J-12R- F01V08-S U03U02-N		R	12	220	500	2400	76.58	124.16	3/4-16UNFx15	Ø 30	9/16-18UNFx13	Ø 25
J-12L- F01V08-S U03U02-N		L										
J-11R- F01V08-S U03U02-N		R	11	235	500	2500	75.25	121.50	3/4-16UNFx15	Ø 30	9/16-18UNFx13	Ø 25
J-11L- F01V08-S U03U02-N		L										
J-10R- F01V08-S U03U02-N		R	10	250	500	2800	73.91	118.82	3/4-16UNFx15	Ø 30	9/16-18UNFx13	Ø 25
J-10L- F01V08-S U03U02-N		L										
J-8R- F01V08-S U03U02-N		R	8	280	500	3100	71.24	113.49	3/4-16UNFx15	Ø 30	9/16-18UNFx13	Ø 25
J-8L- F01V08-S U03U02-N		L										
J-7R- F01V08-S U03U02-N		R	7	280	500	3500	69.91	110.82	3/4-16UNFx15	Ø 30	9/16-18UNFx13	Ø 25
J-7L- F01V08-S U03U02-N		L										
J-6R- F01V08-S U03U02-N		R	6	280	500	3600	68.57	108.14	3/4-16UNFx15	Ø 30	9/16-18UNFx13	Ø 25
J-6L- F01V08-S U03U02-N		L										
J-5R- F01V08-S U03U02-N		R	5	280	500	4000	67.24	105.48	3/4-16UNFx15	Ø 30	9/16-18UNFx13	Ø 25
J-5L- F01V08-S U03U02-N		L										
J-4R- F01V08-S U03U02-N		R	4	280	500	4000	65.90	102.81	3/4-16UNFx15	Ø 30	9/16-18UNFx13	Ø 25
J-4L- F01V08-S U03U02-N		L										
J-3R- F01V08-S U03U02-N		R	3	280	500	4000	64.57	100.14	3/4-16UNFx15	Ø 30	9/16-18UNFx13	Ø 25
J-3L- F01V08-S U03U02-N		L										
J-2R- F01V08-S U03U02-N		R	2	280	500	4000	63.23	97.46	3/4-16UNFx15	Ø 30	9/16-18UNFx13	Ø 25
J-2L- F01V08-S U03U02-N		L										

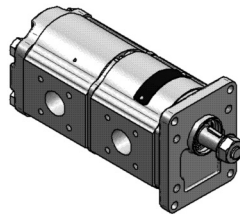
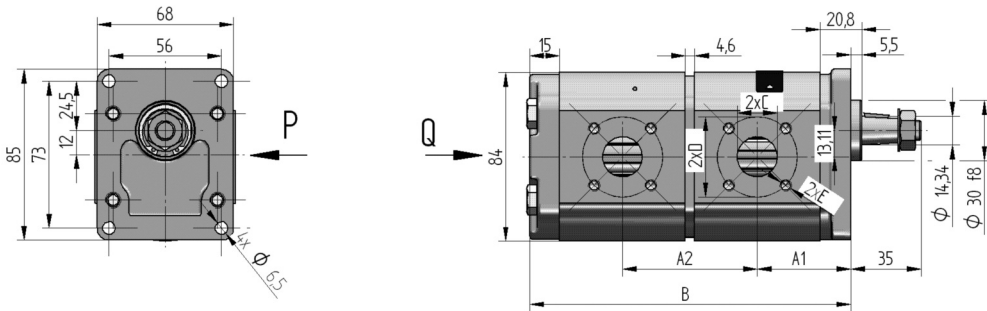

4 x SCREW M 8

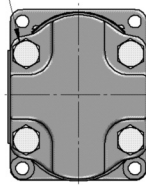

Q

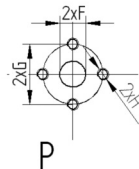

P

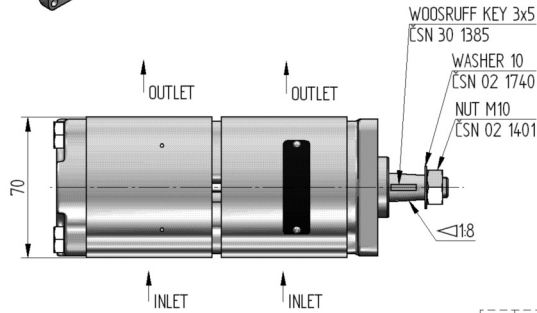

THE CLOCKWISE PUMP IS DRAWN

Order key	purch. code	direct. of rot.	displacement [cm <sup>3</sup> /1]	nom. press. [bar]	speed MIN. [min <sup>-1</sup> ]	speed MAX. [min <sup>-1</sup> ]	dimension								
							A1 [mm]	A2 [mm]	B [mm]	C [mm]	D [mm]	E [mm]	F [mm]	G [mm]	H [mm]
J-15/15R-R03C05-S H06K01/H05K01-N		R	15	190	500	2200	51.86	129.58	181.14	∅20	∅40	M6	∅13.5	∅30	M6
J-15/15L-R03C05-S H06K01/H05K01-N		L													
J-12/12R-R03C05-S H06K01/H05K01-N		R	12	220	500	2400	47.88	117.64	165.22	∅20	∅40	M6	∅13.5	∅30	M6
J-12/12L-R03C05-S H06K01/H05K01-N		L													
J-11/11R-R03C05-S H06K01/H05K01-N	189 9004	R	11	235	500	2500	46.55	113.65	159.90	∅20	∅40	M6	∅13.5	∅30	M6
J-11/11L-R03C05-S H06K01/H05K01-N		L													
J-10/10R-R03C05-S H06K01/H05K01-N		R	10	250	500	2800	45.21	109.63	154.54	∅20	∅40	M6	∅13.5	∅30	M6
J-10/10L-R03C05-S H06K01/H05K01-N		L													
J-8/8R-R03C05-S H06K01/H05K01-N		R	8	280	500	3100	42.54	101.63	143.88	∅20	∅40	M6	∅13.5	∅30	M6
J-8/8L-R03C05-S H06K01/H05K01-N		L													
J-7/7R-R03C05-S H06K01/H05K01-N		R	7	280	500	3500	41.21	97.63	138.54	∅20	∅40	M6	∅13.5	∅30	M6
J-7/7L-R03C05-S H06K01/H05K01-N		L													
J-6/6R-R03C05-S H06K01/H05K01-N		R	6	280	500	3600	39.87	93.61	113.18	∅20	∅40	M6	∅13.5	∅30	M6
J-6/6L-R03C05-S H06K01/H05K01-N		L													
J-5/5R-R03C05-S H06K01/H05K01-N		R	5	280	500	4000	38.54	89.62	127.86	∅20	∅40	M6	∅13.5	∅30	M6
J-5/5L-R03C05-S H06K01/H05K01-N		L													
J-4/4R-R03C05-S H06K01/H05K01-N		R	4	280	500	4000	37.10	85.61	122.52	∅20	∅40	M6	∅13.5	∅30	M6
J-4/4L-R03C05-S H06K01/H05K01-N		L													
J-3/3R-R03C05-S H06K01/H05K01-N		R	3	280	500	4000	35.87	81.62	117.19	∅20	∅40	M6	∅13.5	∅30	M6
J-3/3L-R03C05-S H06K01/H05K01-N		L													
J-2/2R-R03C05-S H06K01/H05K01-N		R	2	280	500	4000	34.53	77.59	111.82	∅20	∅40	M6	∅13.5	∅30	M6
J-2/2L-R03C05-S H06K01/H05K01-N		L													

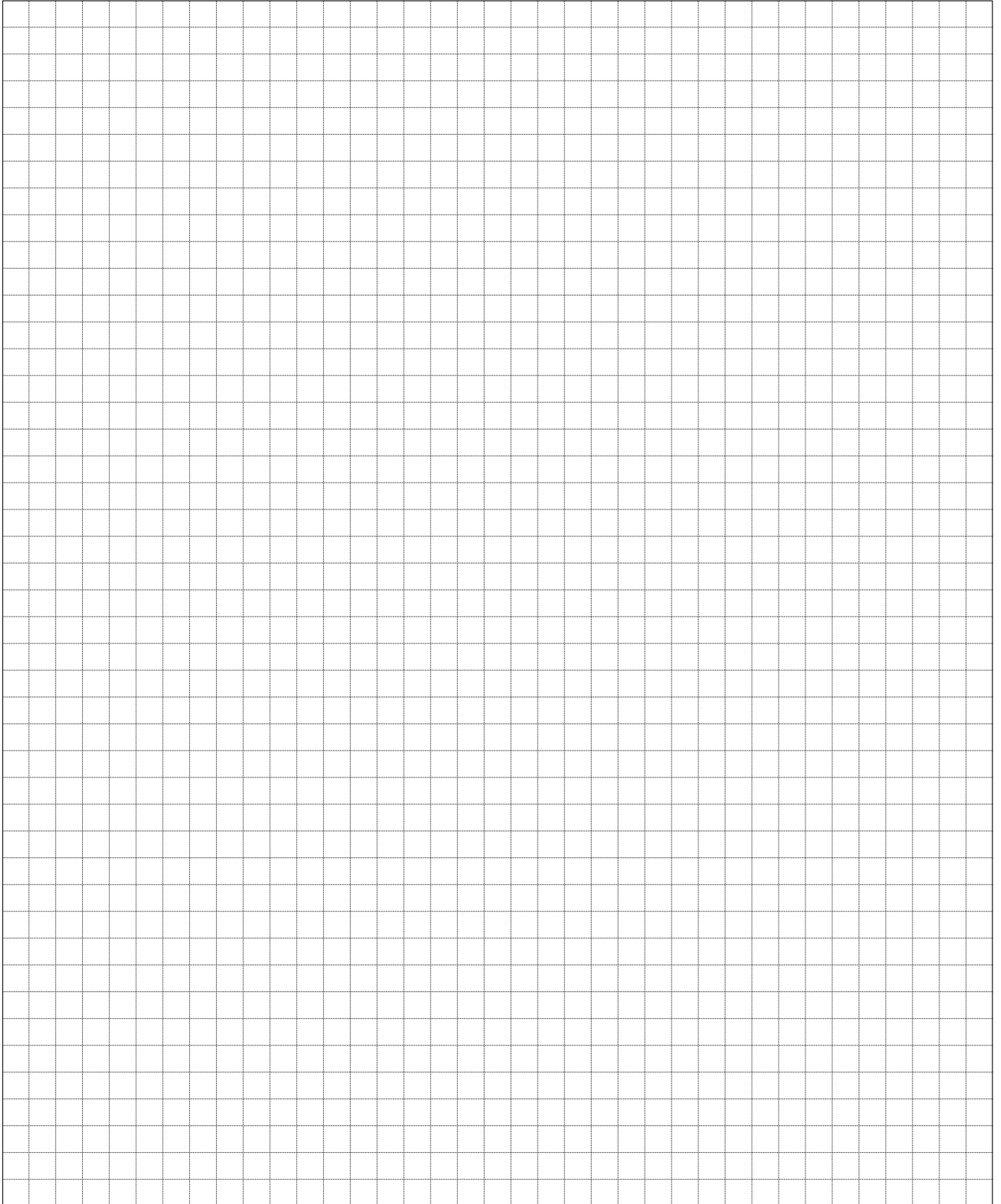

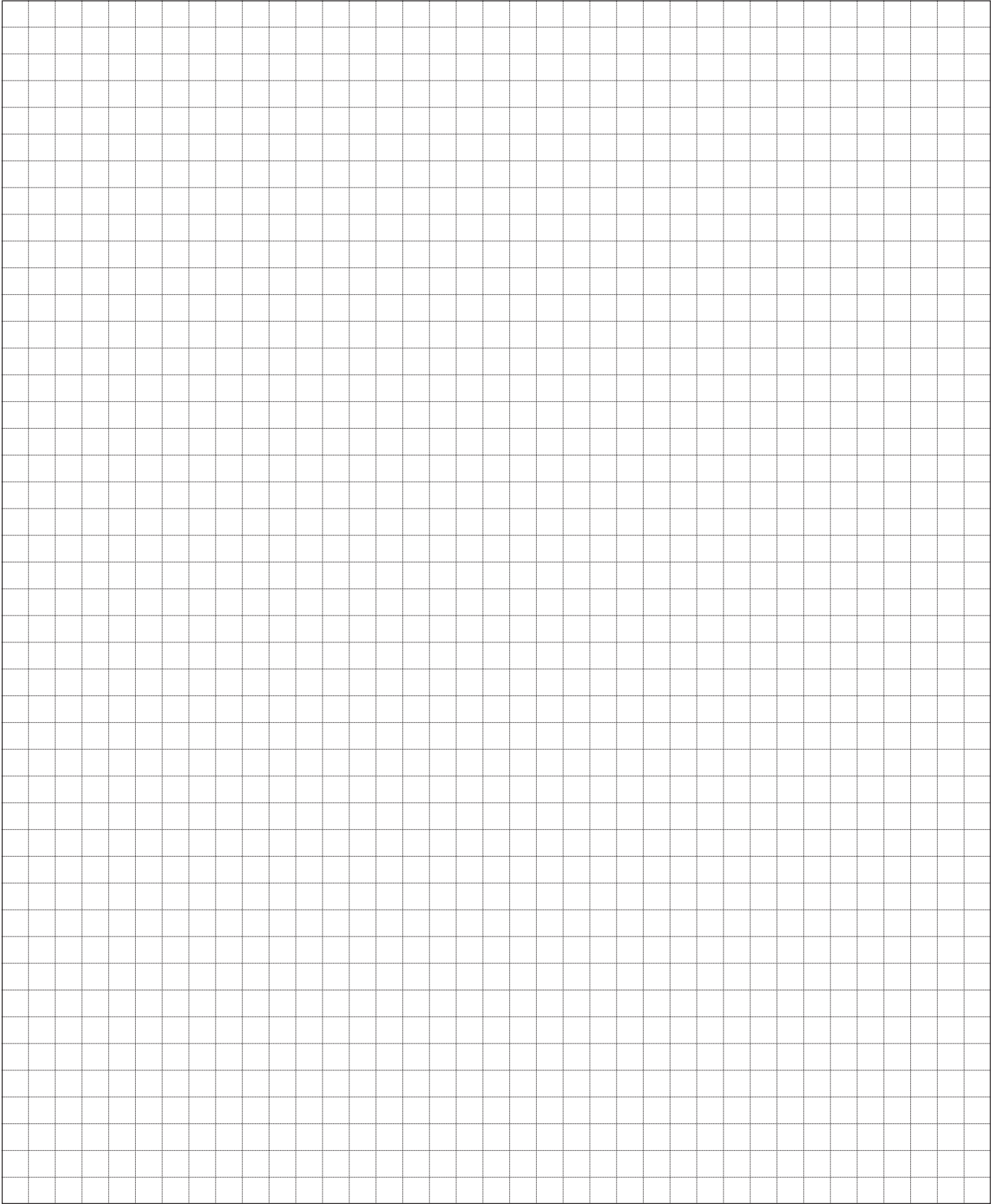

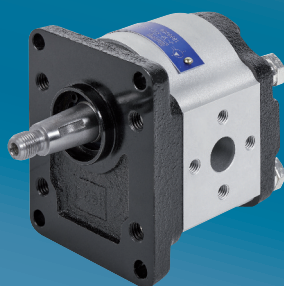

**jihostroj**  
AERO TECHNOLOGY & HYDRAULICS

**JIHOSTROJ a.s.**  
Budějovická 148  
CZ 382 32 Velešín  
Czech Republic  
tel.: +420 380 340 511  
fax: +420 380 340 612  
e-mail: mailbox@jihostroj.cz  
http: //www.jihostroj.com

GPS 48°49'51.748" N 14°27'40.770" E

